

STYLE:

smart

**Magia30**

magia<sup>®</sup>  
fontanot





Copyright by Albini & Fontanot spa, prima pubblicazione 4 aprile 2011



Magia30



10 mm  
13 mm  
19 mm

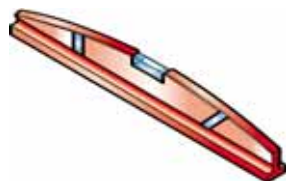

3 mm  
5 mm  
6 mm  
10 mm

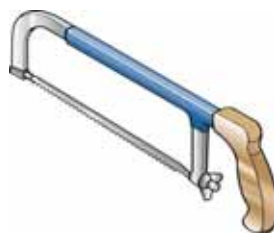

PH 2



Ø 2,5 mm  
Ø 6,5 mm



Ø 8 x 120 mm  
Ø 14 x 150 mm



10 mm  
13 mm  
19 mm

1

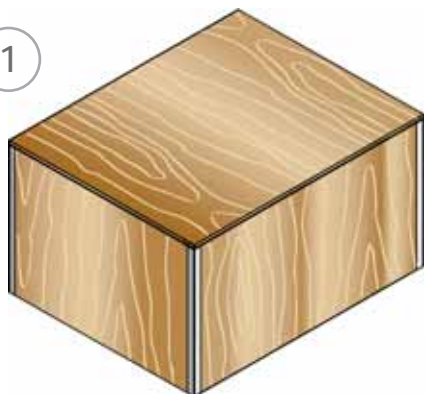

2

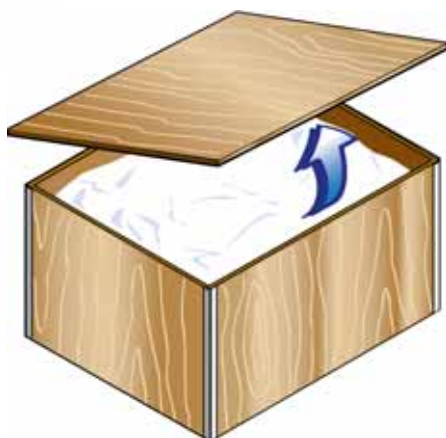



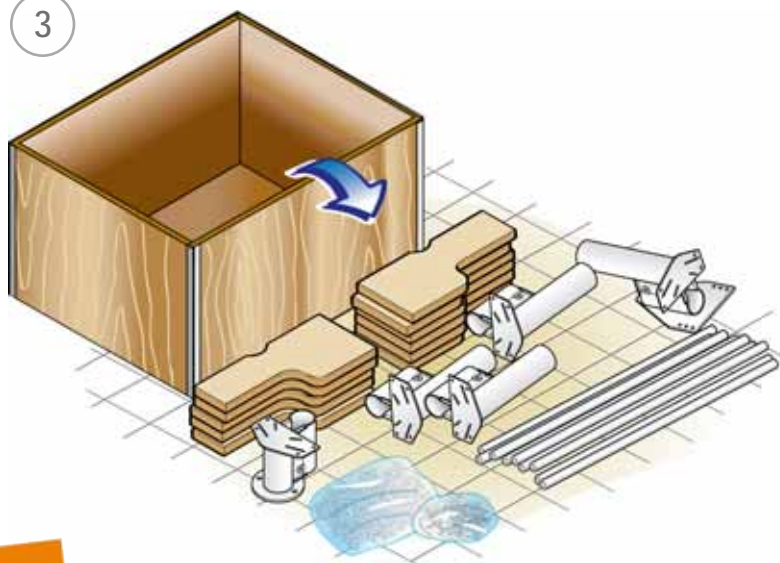



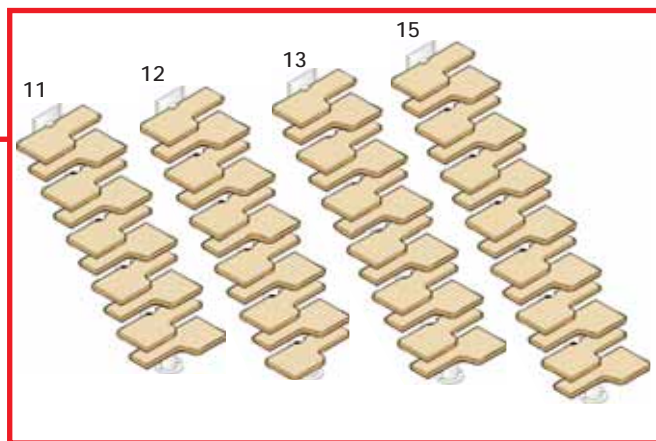

3



|    |    |    |    |
|----|----|----|----|
| 11 | 12 | 13 | 15 |
| 2  | 3  | 3  | 4  |



|  |    |    |    |    |    |    |    |    |  |    |    |    |    |    |    |    |    |   |    |    |    |    |    |    |    |    |
|--|----|----|----|----|----|----|----|----|--|----|----|----|----|----|----|----|----|---|----|----|----|----|----|----|----|----|
| <p>A21 ↔ A37</p>  <table border="1" data-bbox="252 845 392 893"> <tr> <td>11</td> <td>12</td> <td>13</td> <td>15</td> </tr> <tr> <td>2</td> <td>2</td> <td>2</td> <td>2</td> </tr> </table>   | 11 | 12 | 13 | 15 | 2  | 2  | 2  | 2  | <p>A22</p>  <table border="1" data-bbox="560 845 700 893"> <tr> <td>11</td> <td>12</td> <td>13</td> <td>15</td> </tr> <tr> <td>3</td> <td>4</td> <td>4</td> <td>4</td> </tr> </table>         | 11 | 12 | 13 | 15 | 3  | 4  | 4  | 4  | <p>B02</p>  <table border="1" data-bbox="868 845 1013 893"> <tr> <td>11</td> <td>12</td> <td>13</td> <td>15</td> </tr> <tr> <td>23</td> <td>25</td> <td>27</td> <td>31</td> </tr> </table>     | 11 | 12 | 13 | 15 | 23 | 25 | 27 | 31 |
| 11   | 12 | 13 | 15 |    |    |    |    |    |  |    |    |    |    |    |    |    |    |   |    |    |    |    |    |    |    |    |
| 2  | 2  | 2  | 2  |    |    |    |    |    |  |    |    |    |    |    |    |    |    |   |    |    |    |    |    |    |    |    |
| 11   | 12 | 13 | 15 |    |    |    |    |    |  |    |    |    |    |    |    |    |    |   |    |    |    |    |    |    |    |    |
| 3  | 4  | 4  | 4  |    |    |    |    |    |  |    |    |    |    |    |    |    |    |   |    |    |    |    |    |    |    |    |
| 11   | 12 | 13 | 15 |    |    |    |    |    |  |    |    |    |    |    |    |    |    |   |    |    |    |    |    |    |    |    |
| 23   | 25 | 27 | 31 |    |    |    |    |    |  |    |    |    |    |    |    |    |    |   |    |    |    |    |    |    |    |    |
| <p>B12</p>  <table border="1" data-bbox="252 1109 392 1157"> <tr> <td>11</td> <td>12</td> <td>13</td> <td>15</td> </tr> <tr> <td>4</td> <td>4</td> <td>4</td> <td>4</td> </tr> </table>      | 11 | 12 | 13 | 15 | 4  | 4  | 4  | 4  | <p>B33</p>  <table border="1" data-bbox="560 1109 700 1157"> <tr> <td>11</td> <td>12</td> <td>13</td> <td>15</td> </tr> <tr> <td>2</td> <td>3</td> <td>3</td> <td>3</td> </tr> </table>      | 11 | 12 | 13 | 15 | 2  | 3  | 3  | 3  | <p>B71</p>  <table border="1" data-bbox="868 1109 1013 1157"> <tr> <td>11</td> <td>12</td> <td>13</td> <td>15</td> </tr> <tr> <td>18</td> <td>20</td> <td>22</td> <td>26</td> </tr> </table>  | 11 | 12 | 13 | 15 | 18 | 20 | 22 | 26 |
| 11   | 12 | 13 | 15 |    |    |    |    |    |  |    |    |    |    |    |    |    |    |   |    |    |    |    |    |    |    |    |
| 4  | 4  | 4  | 4  |    |    |    |    |    |  |    |    |    |    |    |    |    |    |   |    |    |    |    |    |    |    |    |
| 11   | 12 | 13 | 15 |    |    |    |    |    |  |    |    |    |    |    |    |    |    |   |    |    |    |    |    |    |    |    |
| 2  | 3  | 3  | 3  |    |    |    |    |    |  |    |    |    |    |    |    |    |    |   |    |    |    |    |    |    |    |    |
| 11   | 12 | 13 | 15 |    |    |    |    |    |  |    |    |    |    |    |    |    |    |   |    |    |    |    |    |    |    |    |
| 18   | 20 | 22 | 26 |    |    |    |    |    |  |    |    |    |    |    |    |    |    |   |    |    |    |    |    |    |    |    |
| <p>B75</p>  <table border="1" data-bbox="252 1372 392 1420"> <tr> <td>11</td> <td>12</td> <td>13</td> <td>15</td> </tr> <tr> <td>36</td> <td>40</td> <td>44</td> <td>52</td> </tr> </table> | 11 | 12 | 13 | 15 | 36 | 40 | 44 | 52 | <p>B82</p>  <table border="1" data-bbox="560 1372 700 1420"> <tr> <td>11</td> <td>12</td> <td>13</td> <td>15</td> </tr> <tr> <td>10</td> <td>11</td> <td>12</td> <td>14</td> </tr> </table> | 11 | 12 | 13 | 15 | 10 | 11 | 12 | 14 | <p>B83</p>  <table border="1" data-bbox="868 1372 1013 1420"> <tr> <td>11</td> <td>12</td> <td>13</td> <td>15</td> </tr> <tr> <td>44</td> <td>48</td> <td>52</td> <td>60</td> </tr> </table> | 11 | 12 | 13 | 15 | 44 | 48 | 52 | 60 |
| 11   | 12 | 13 | 15 |    |    |    |    |    |  |    |    |    |    |    |    |    |    |   |    |    |    |    |    |    |    |    |
| 36   | 40 | 44 | 52 |    |    |    |    |    |  |    |    |    |    |    |    |    |    |   |    |    |    |    |    |    |    |    |
| 11   | 12 | 13 | 15 |    |    |    |    |    |  |    |    |    |    |    |    |    |    |   |    |    |    |    |    |    |    |    |
| 10   | 11 | 12 | 14 |    |    |    |    |    |  |    |    |    |    |    |    |    |    |   |    |    |    |    |    |    |    |    |
| 11   | 12 | 13 | 15 |    |    |    |    |    |  |    |    |    |    |    |    |    |    |   |    |    |    |    |    |    |    |    |
| 44   | 48 | 52 | 60 |    |    |    |    |    |  |    |    |    |    |    |    |    |    |   |    |    |    |    |    |    |    |    |

C03



|    |    |    |    |
|----|----|----|----|
| 11 | 12 | 13 | 15 |
| 11 | 12 | 13 | 15 |

C13



|    |    |    |    |
|----|----|----|----|
| 11 | 12 | 13 | 15 |
| 22 | 24 | 26 | 30 |

C14



|    |    |    |    |
|----|----|----|----|
| 11 | 12 | 13 | 15 |
| 22 | 24 | 26 | 30 |

C15



|    |    |    |    |
|----|----|----|----|
| 11 | 12 | 13 | 15 |
| 18 | 20 | 22 | 26 |

C39



|    |    |    |    |
|----|----|----|----|
| 11 | 12 | 13 | 15 |
| 4  | 4  | 4  | 4  |

C49



|    |    |    |    |
|----|----|----|----|
| 11 | 12 | 13 | 15 |
| 23 | 25 | 27 | 31 |

C50



|    |    |    |    |
|----|----|----|----|
| 11 | 12 | 13 | 15 |
| 1  | 1  | 1  | 1  |

C57



|    |    |    |    |
|----|----|----|----|
| 11 | 12 | 13 | 15 |
| 40 | 44 | 48 | 56 |

C58



|    |    |    |    |
|----|----|----|----|
| 11 | 12 | 13 | 15 |
| 4  | 4  | 4  | 4  |

C63



|    |    |    |    |
|----|----|----|----|
| 11 | 12 | 13 | 15 |
| 11 | 12 | 13 | 15 |

C64



|    |    |    |    |
|----|----|----|----|
| 11 | 12 | 13 | 15 |
| 24 | 26 | 28 | 32 |

C65



|    |    |    |    |
|----|----|----|----|
| 11 | 12 | 13 | 15 |
| 11 | 12 | 13 | 15 |

C66



|    |    |    |    |
|----|----|----|----|
| 11 | 12 | 13 | 15 |
| 11 | 12 | 13 | 15 |

D72



|    |    |    |    |
|----|----|----|----|
| 11 | 12 | 13 | 15 |
| 2  | 3  | 3  | 3  |

F01



|    |    |    |    |
|----|----|----|----|
| 11 | 12 | 13 | 15 |
| 1  | 1  | 1  | 1  |



F08



|    |    |    |    |
|----|----|----|----|
| 11 | 12 | 13 | 15 |
| 2  | 2  | 2  | 2  |

F09



|    |    |    |    |
|----|----|----|----|
| 11 | 12 | 13 | 15 |
| 1  | 1  | 1  | 1  |

F23



|    |    |    |    |
|----|----|----|----|
| 11 | 12 | 13 | 15 |
| 22 | 24 | 26 | 30 |

L19



|    |    |    |    |
|----|----|----|----|
| 11 | 12 | 13 | 15 |
| 5  | 6  | 6  | 7  |

L20



|    |    |    |    |
|----|----|----|----|
| 11 | 12 | 13 | 15 |
| 5  | 5  | 6  | 7  |

N16



|    |    |    |    |
|----|----|----|----|
| 11 | 12 | 13 | 15 |
| 1  | 1  | 1  | 1  |

N17



|    |    |    |    |
|----|----|----|----|
| 11 | 12 | 13 | 15 |
| 7  | 1  | 1  | 1  |

N18



|    |    |    |    |
|----|----|----|----|
| 11 | 12 | 13 | 15 |
| 7  | 8  | 9  | 11 |

N19



|    |    |    |    |
|----|----|----|----|
| 11 | 12 | 13 | 15 |
| 1  | 1  | 1  | 1  |

X01



4

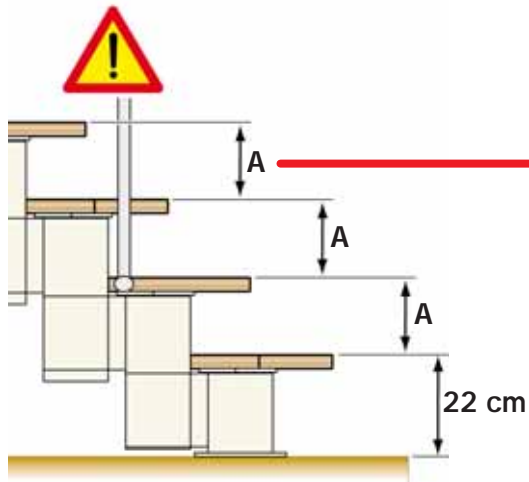



11 (N)



12 (N)

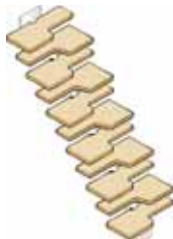

13 (N)



15 (N)

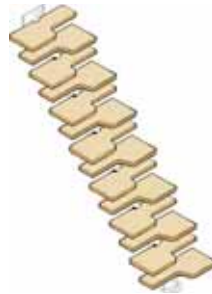

$$A = H - 22 \text{ cm} / N - 1$$

( A = 19 ÷ 23,5 cm )

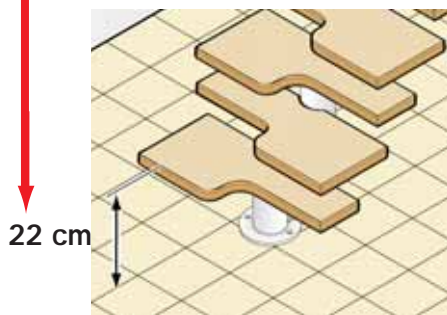
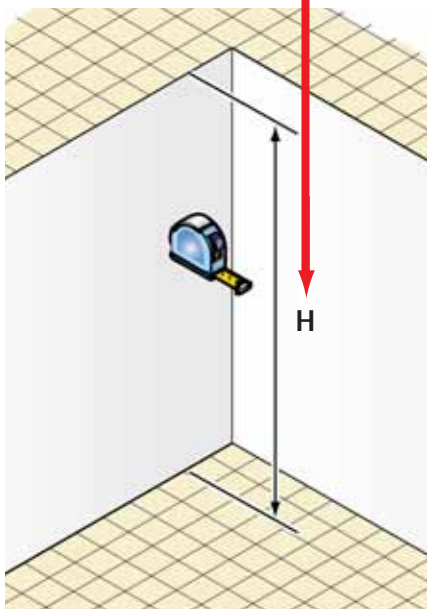

5

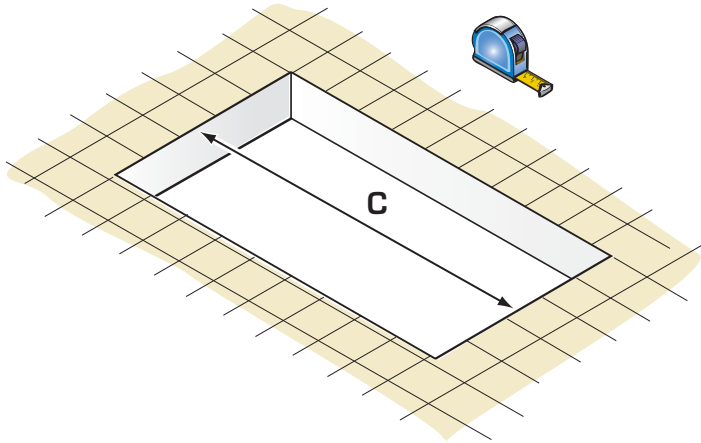

6 a

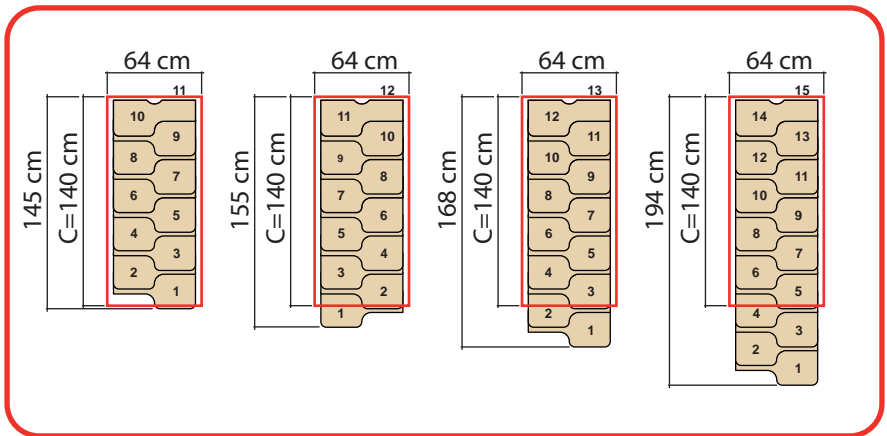

6 b

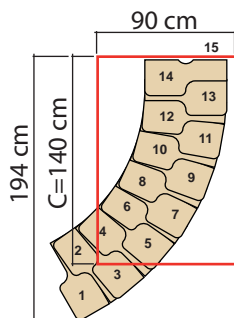
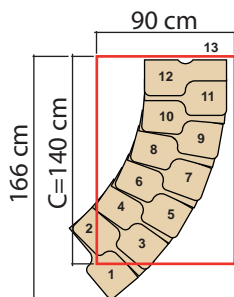
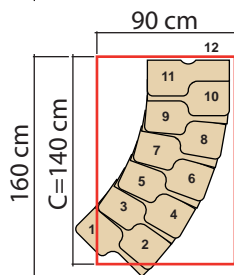
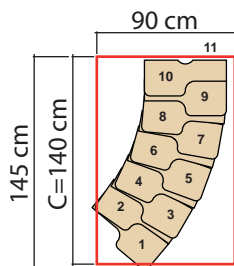
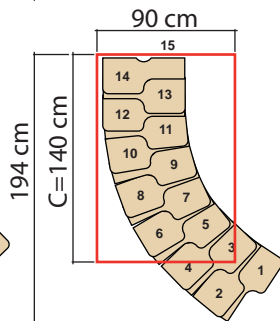
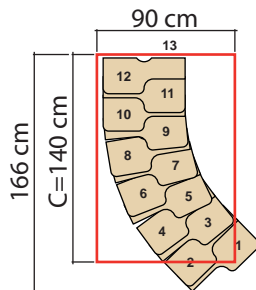
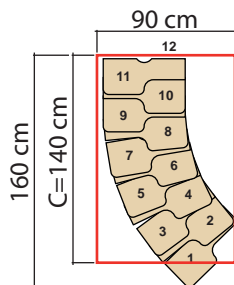
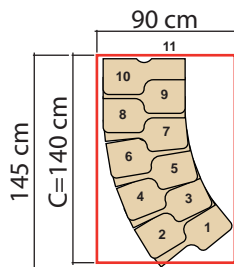
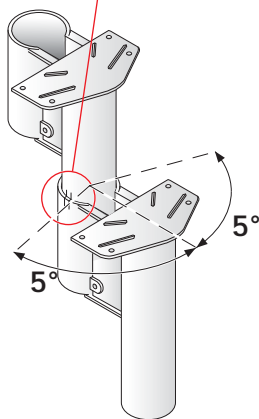
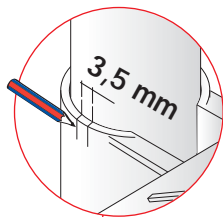

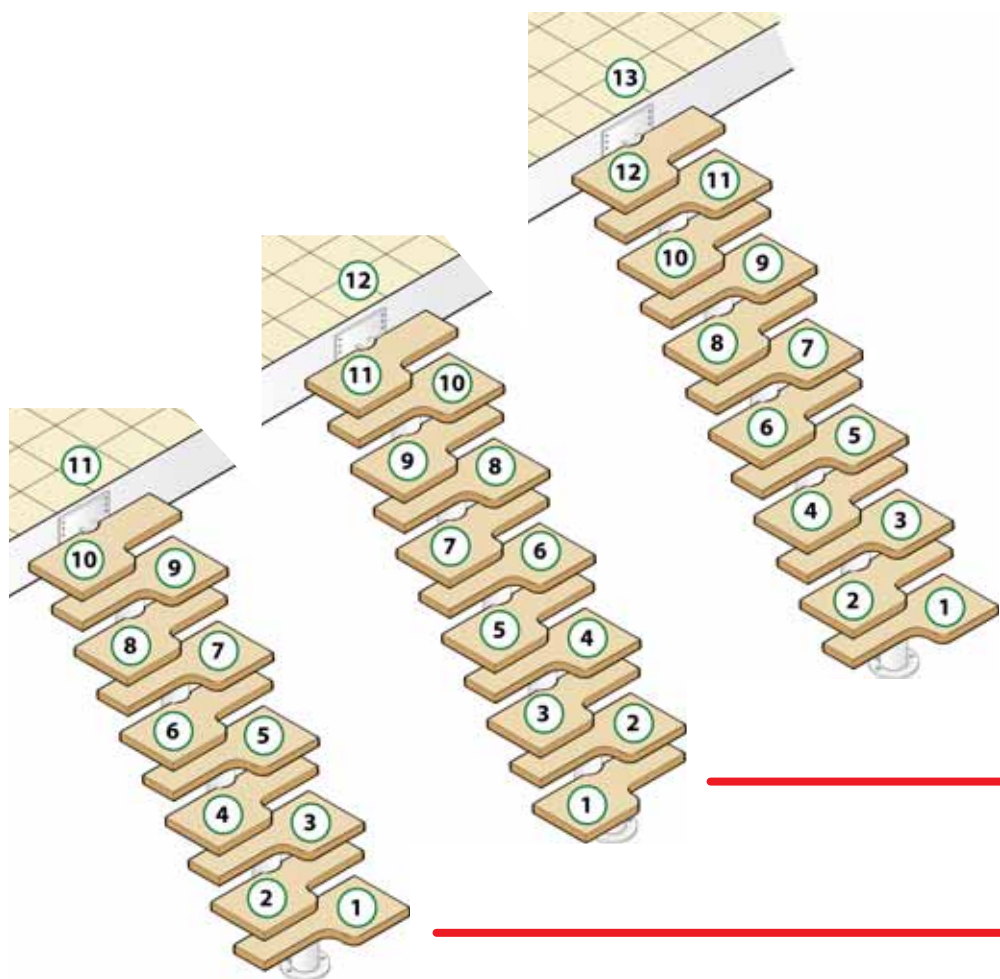

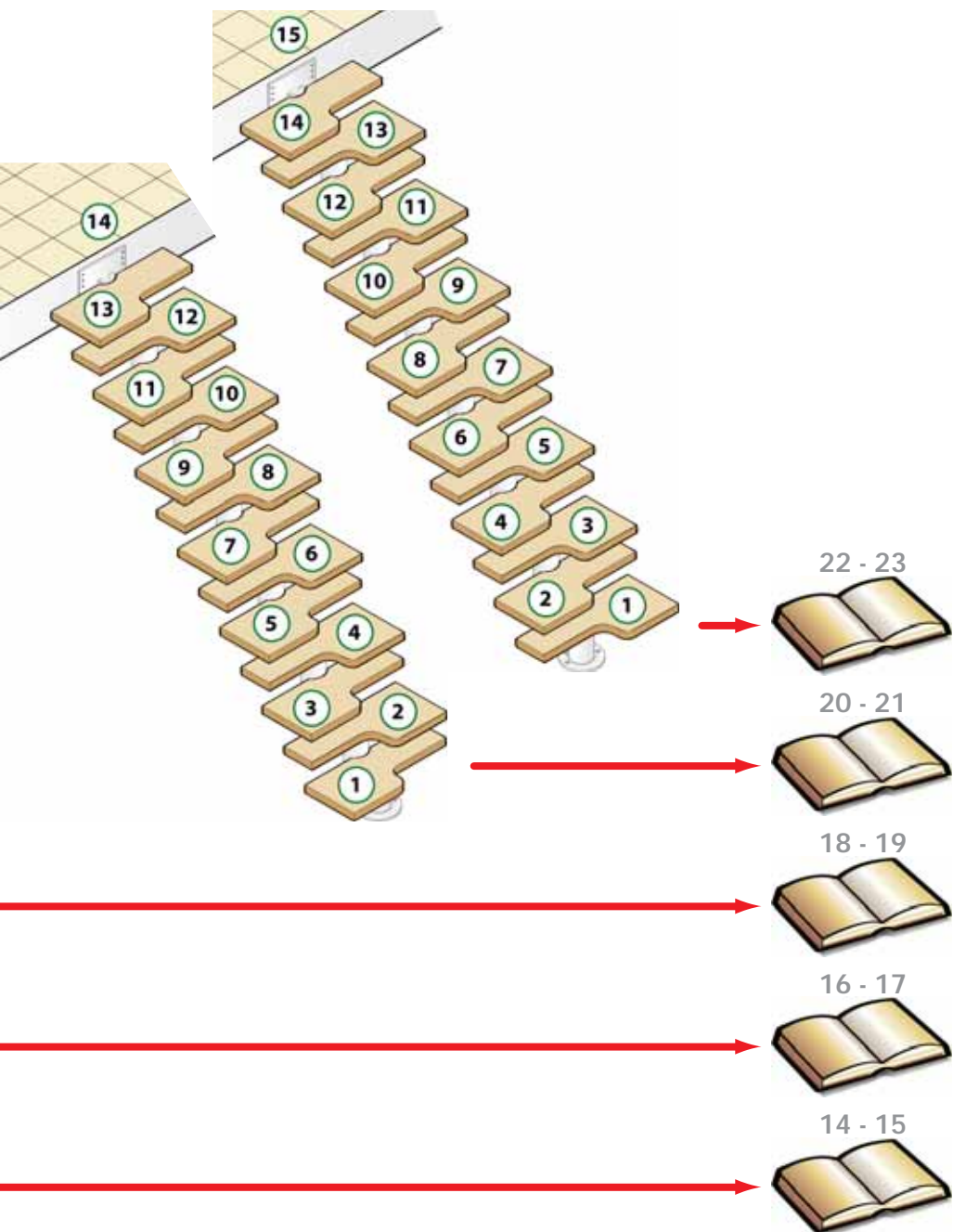

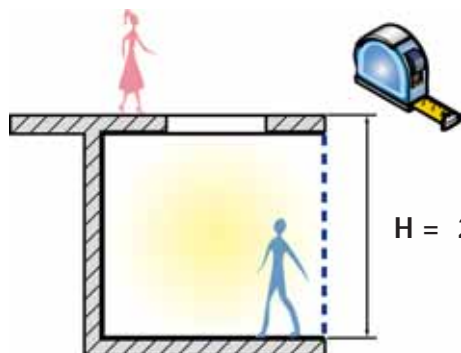

$H = 212 \div 257 \text{ cm}$

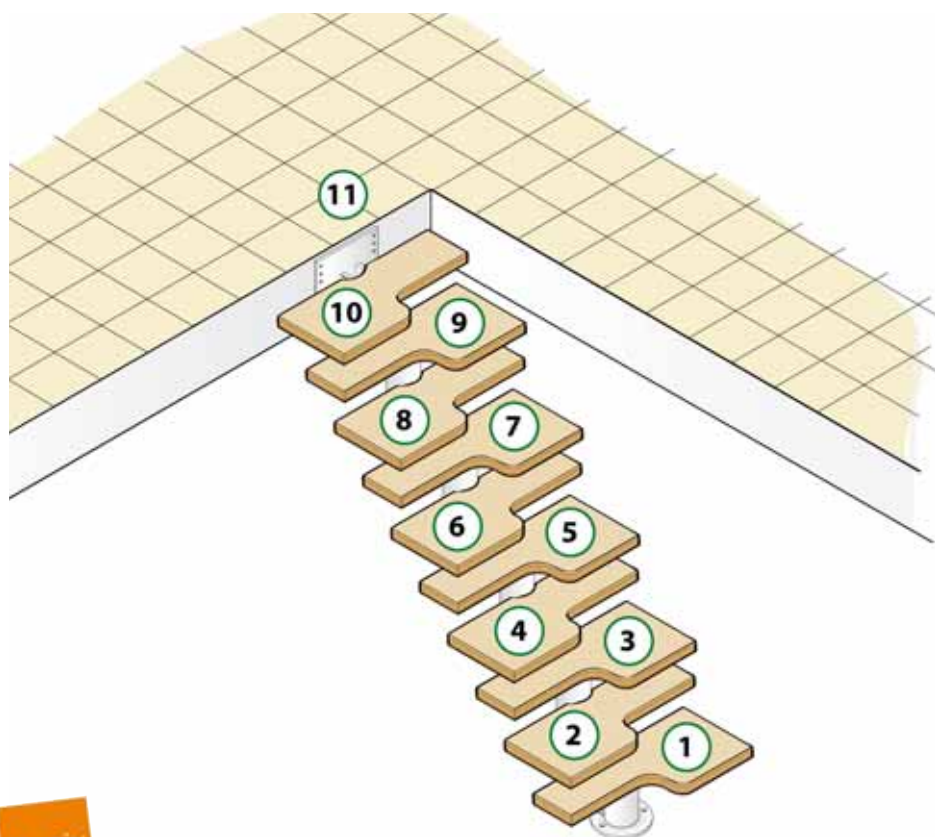

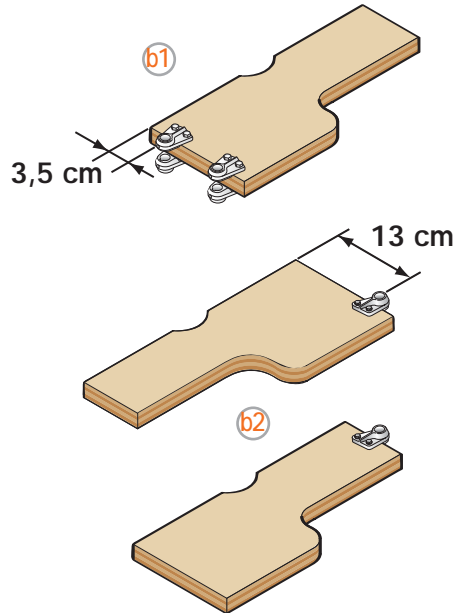
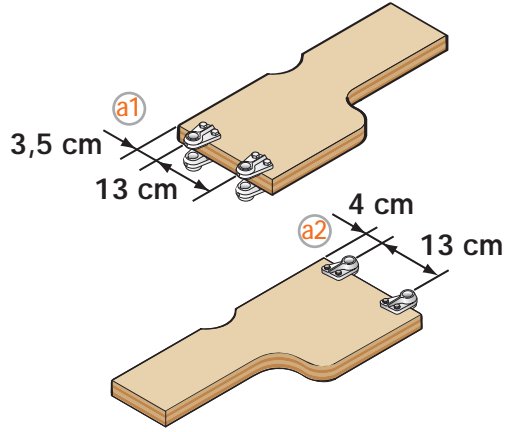
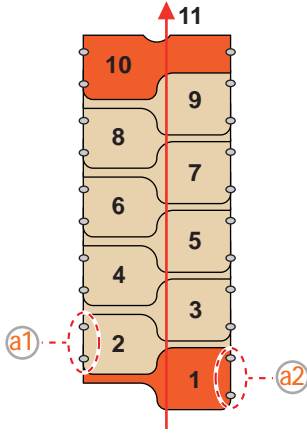

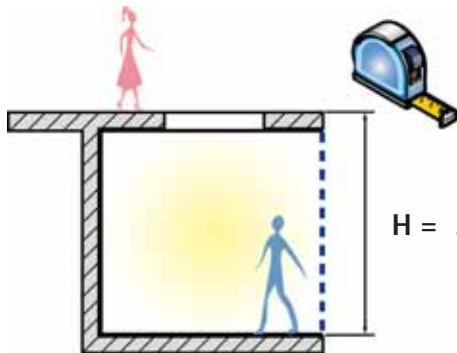

H = 231 ÷ 280 cm

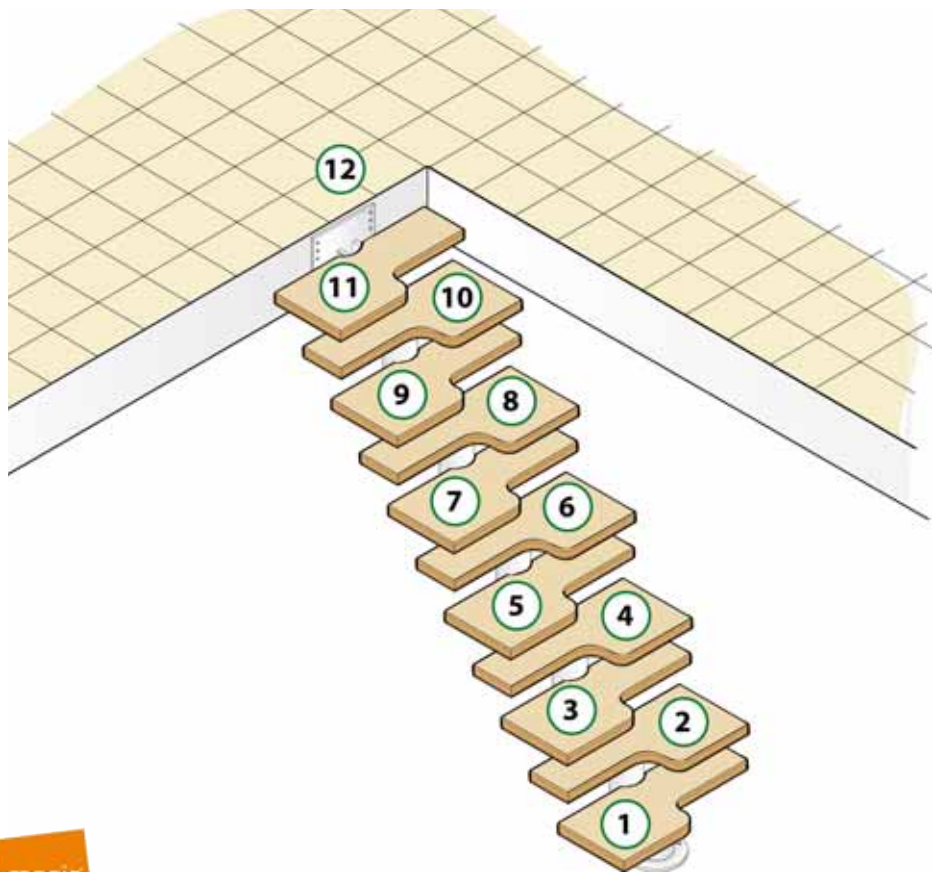



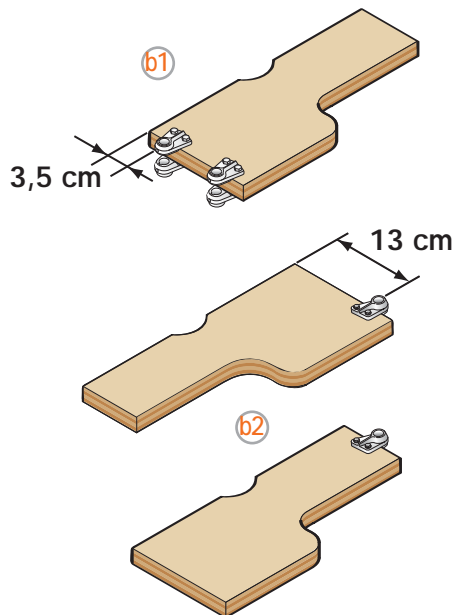
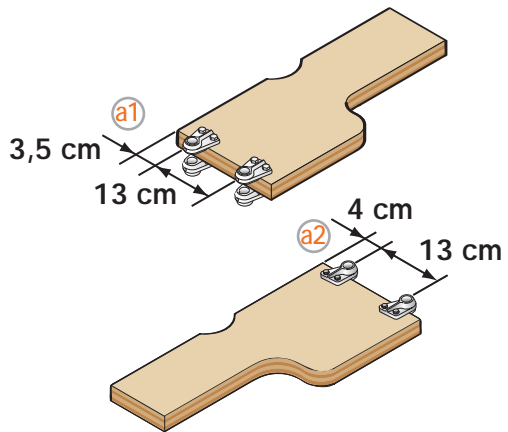
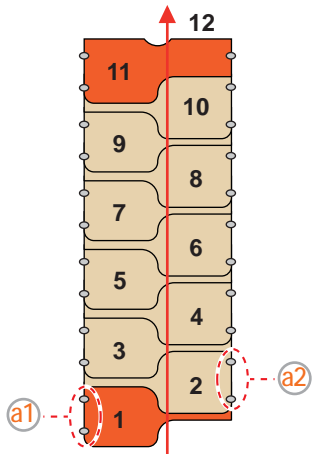

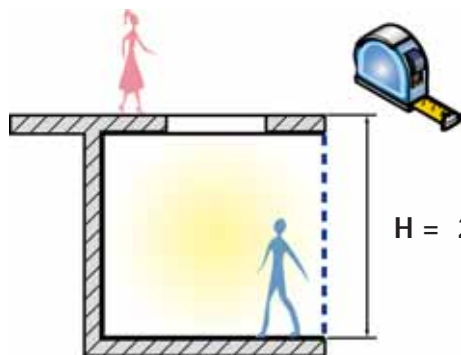

$H = 250 \div 304 \text{ cm}$

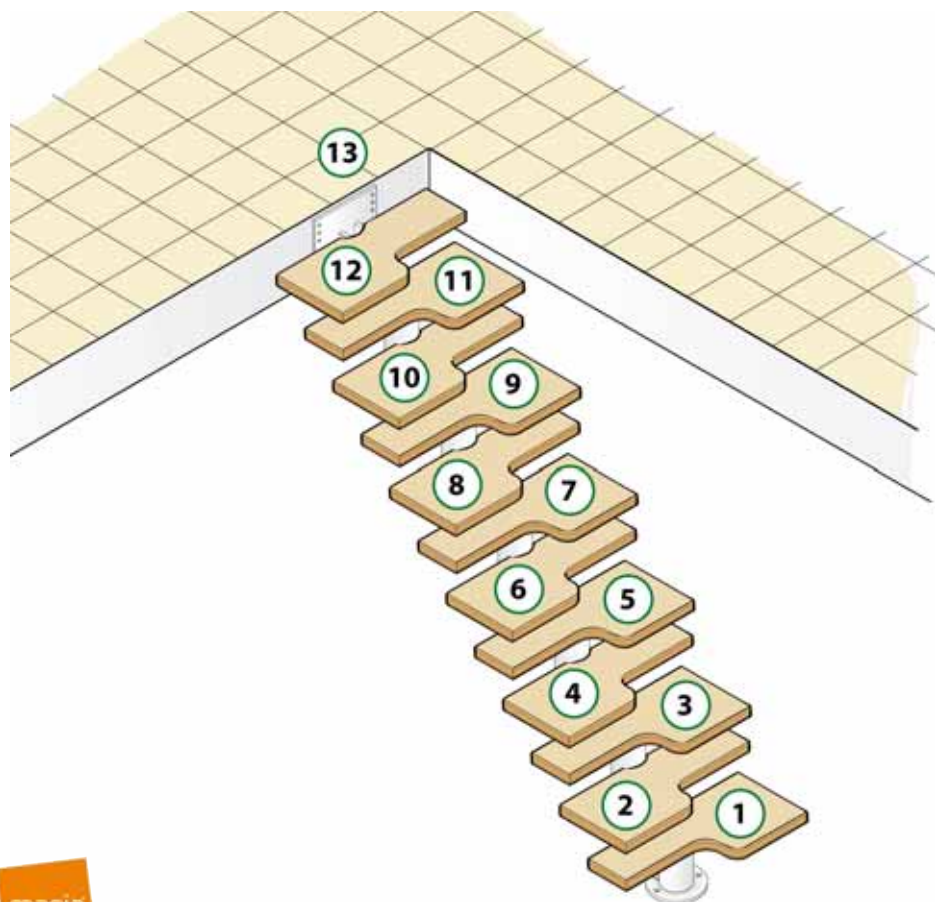

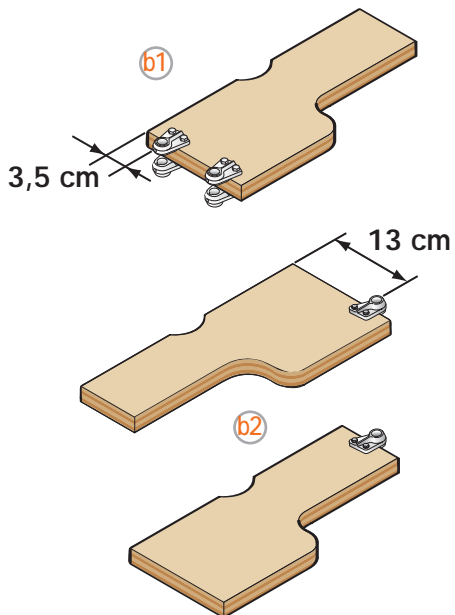
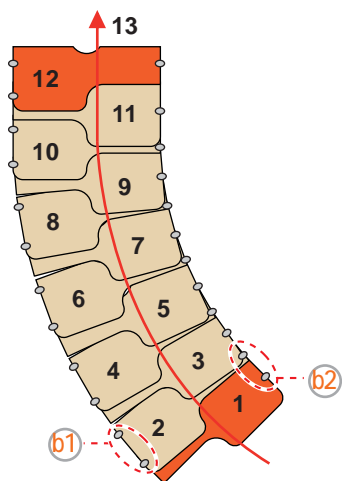
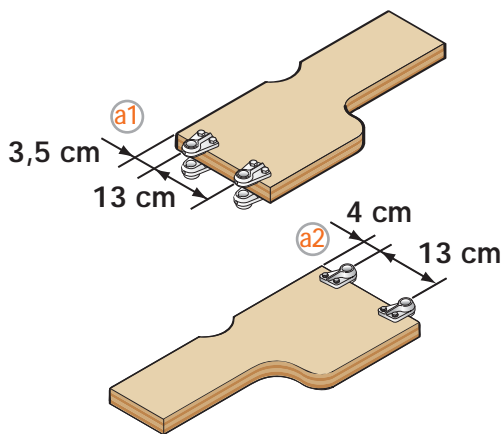
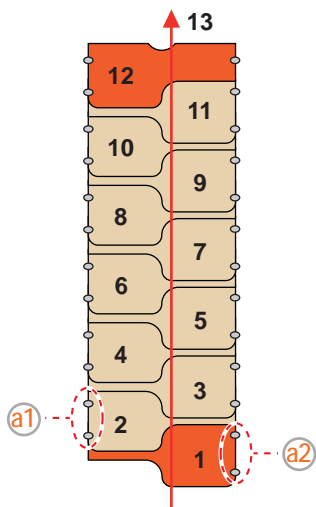

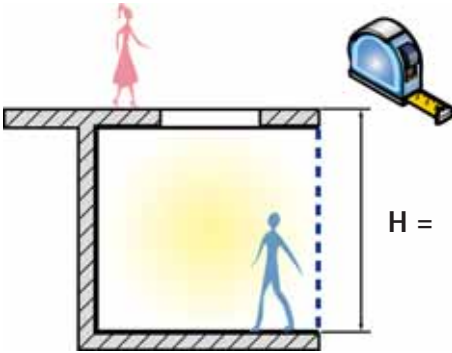

$H = 269 \div 327 \text{ cm}$

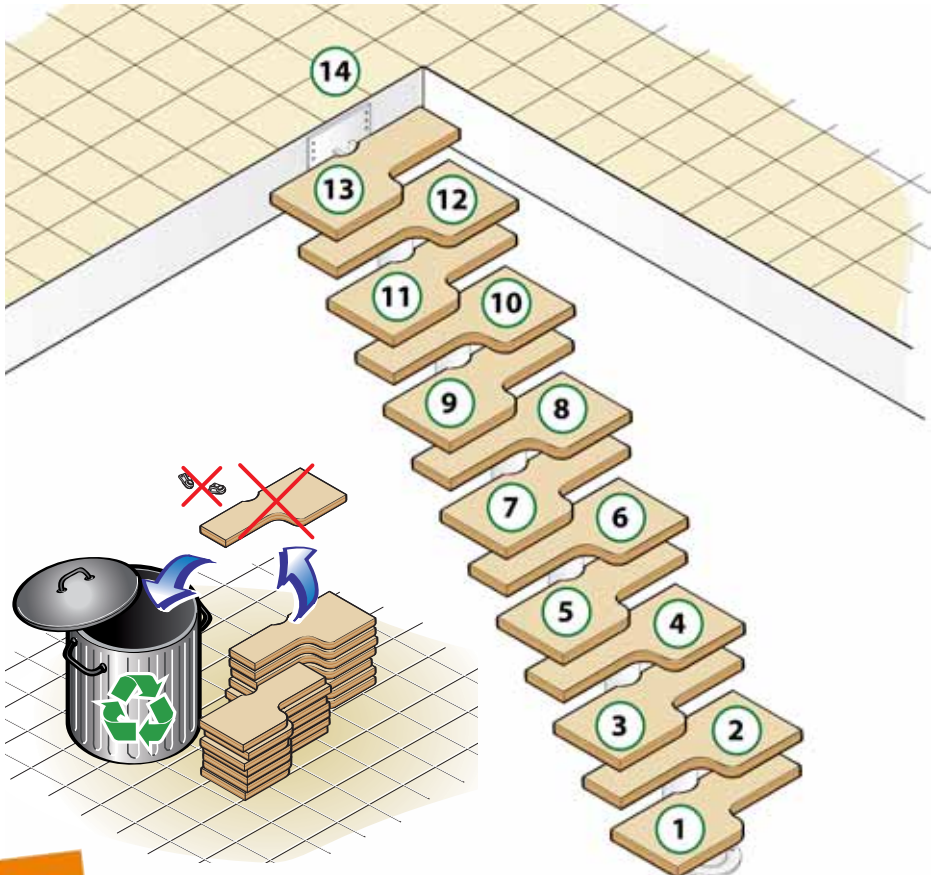

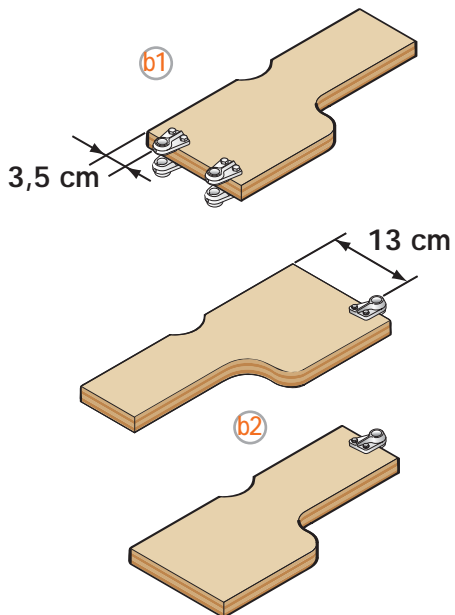
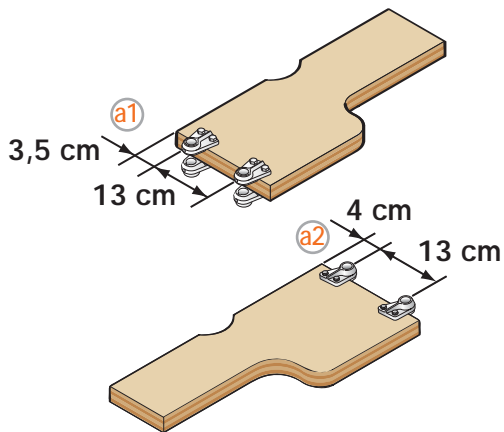
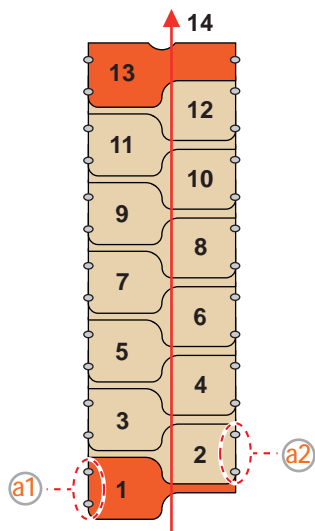

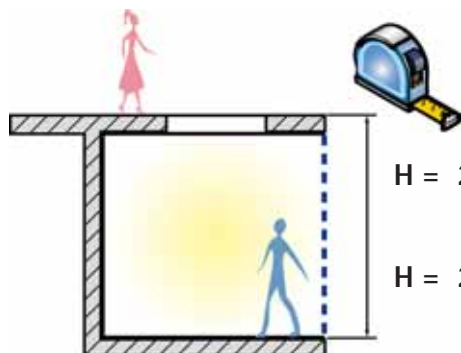

$$H = 269 \div 327 \text{ cm} \quad (14)$$

$$H = 288 \div 351 \text{ cm} \quad (15)$$

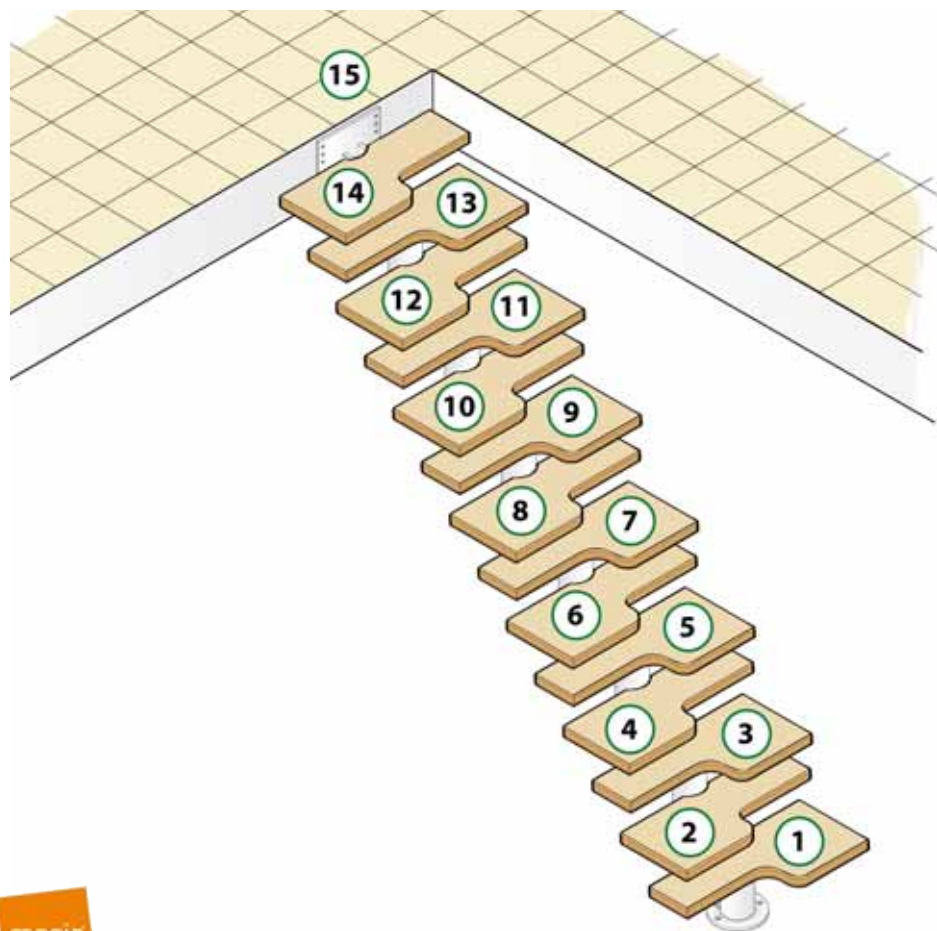

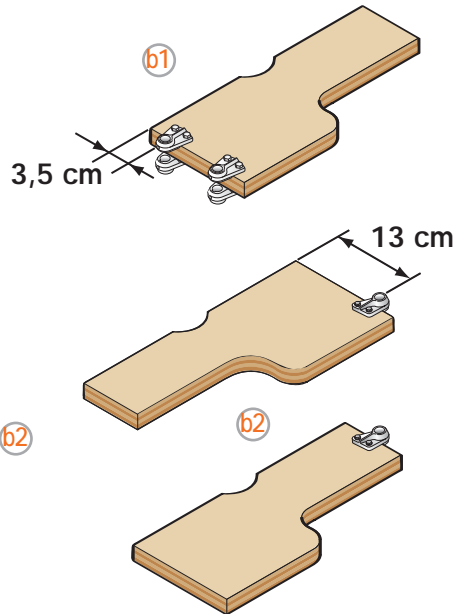
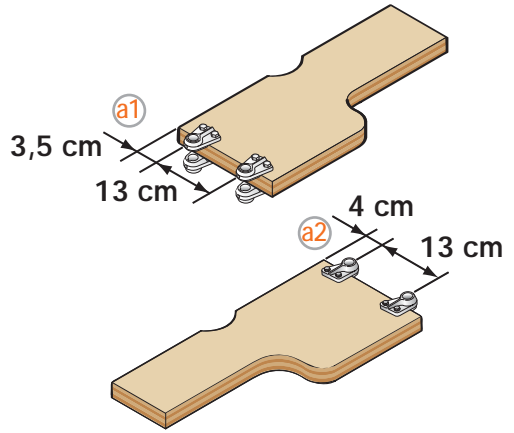
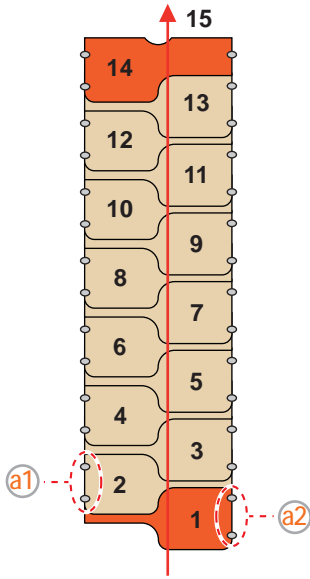

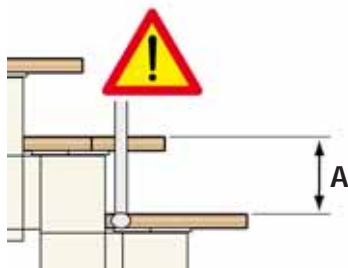
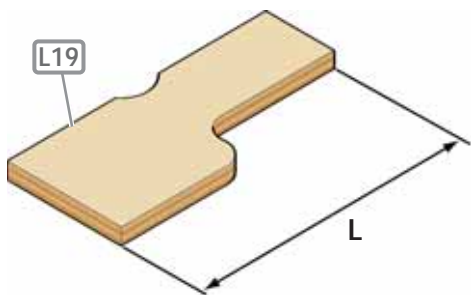
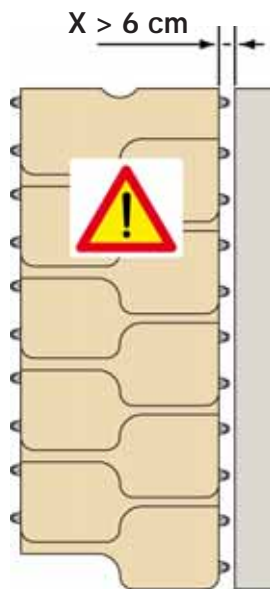
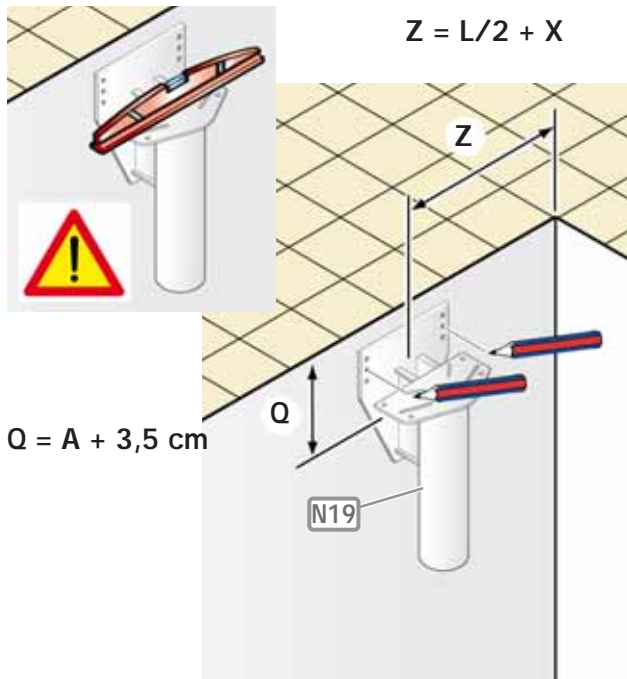



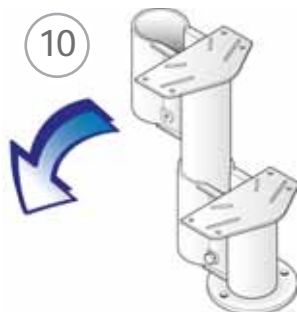
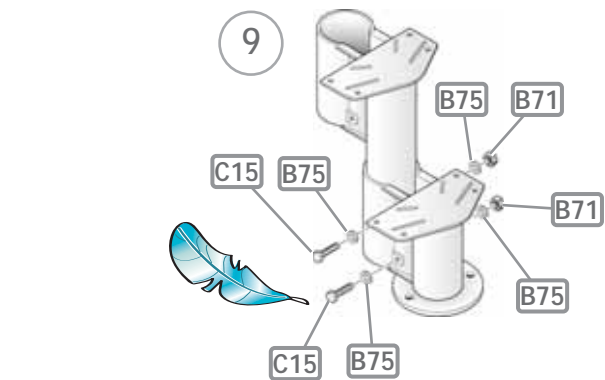
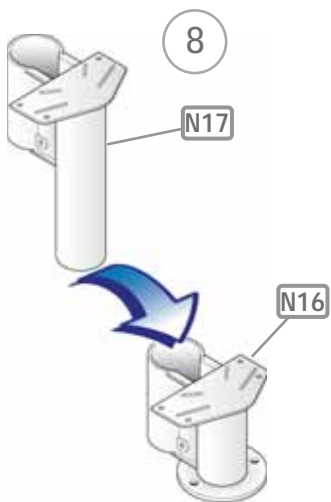
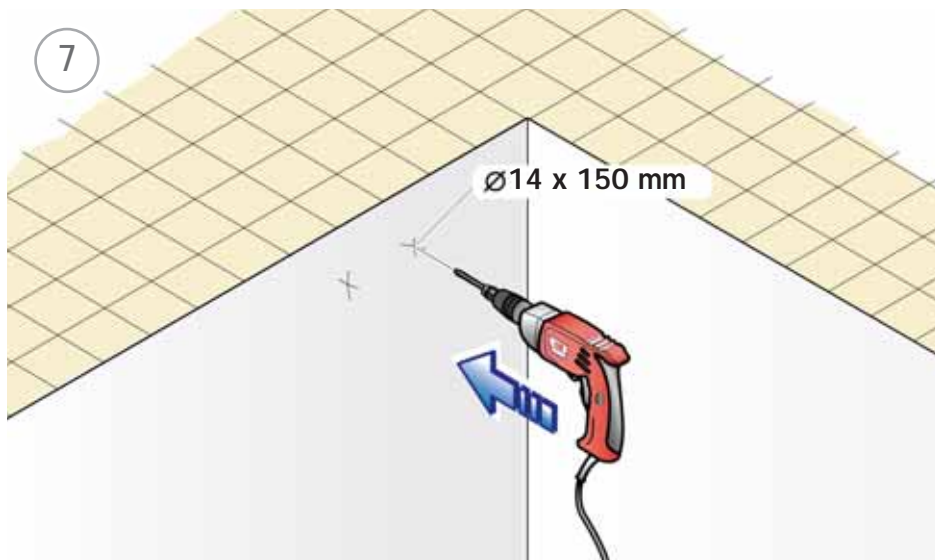

11

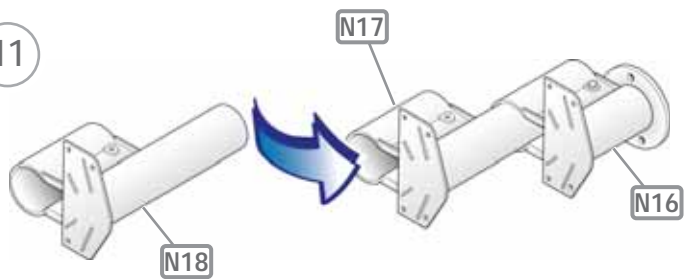

12

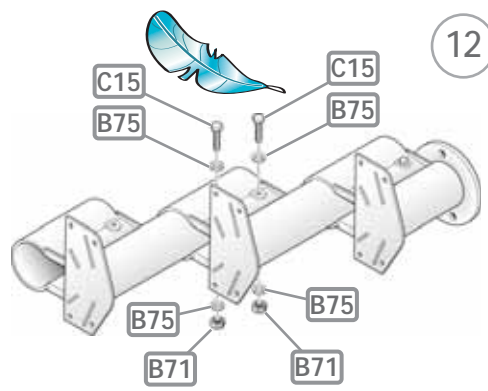

13

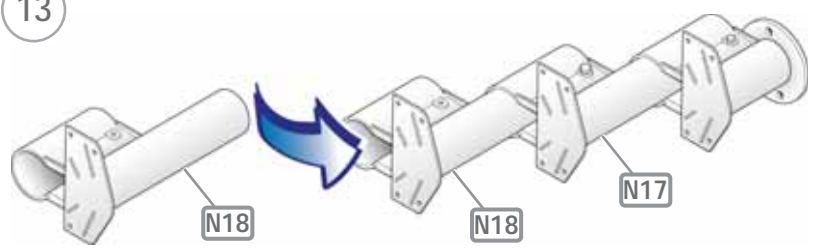

14

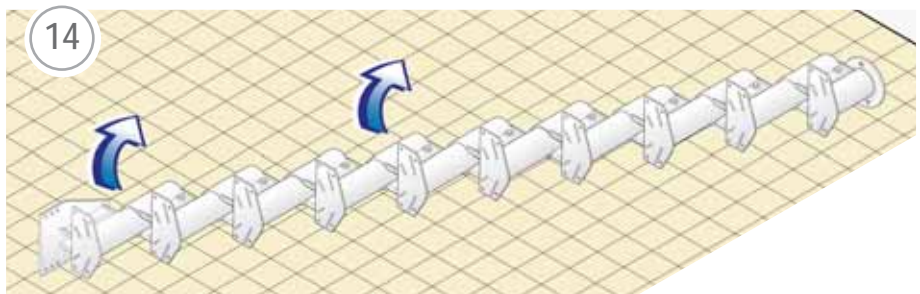

15

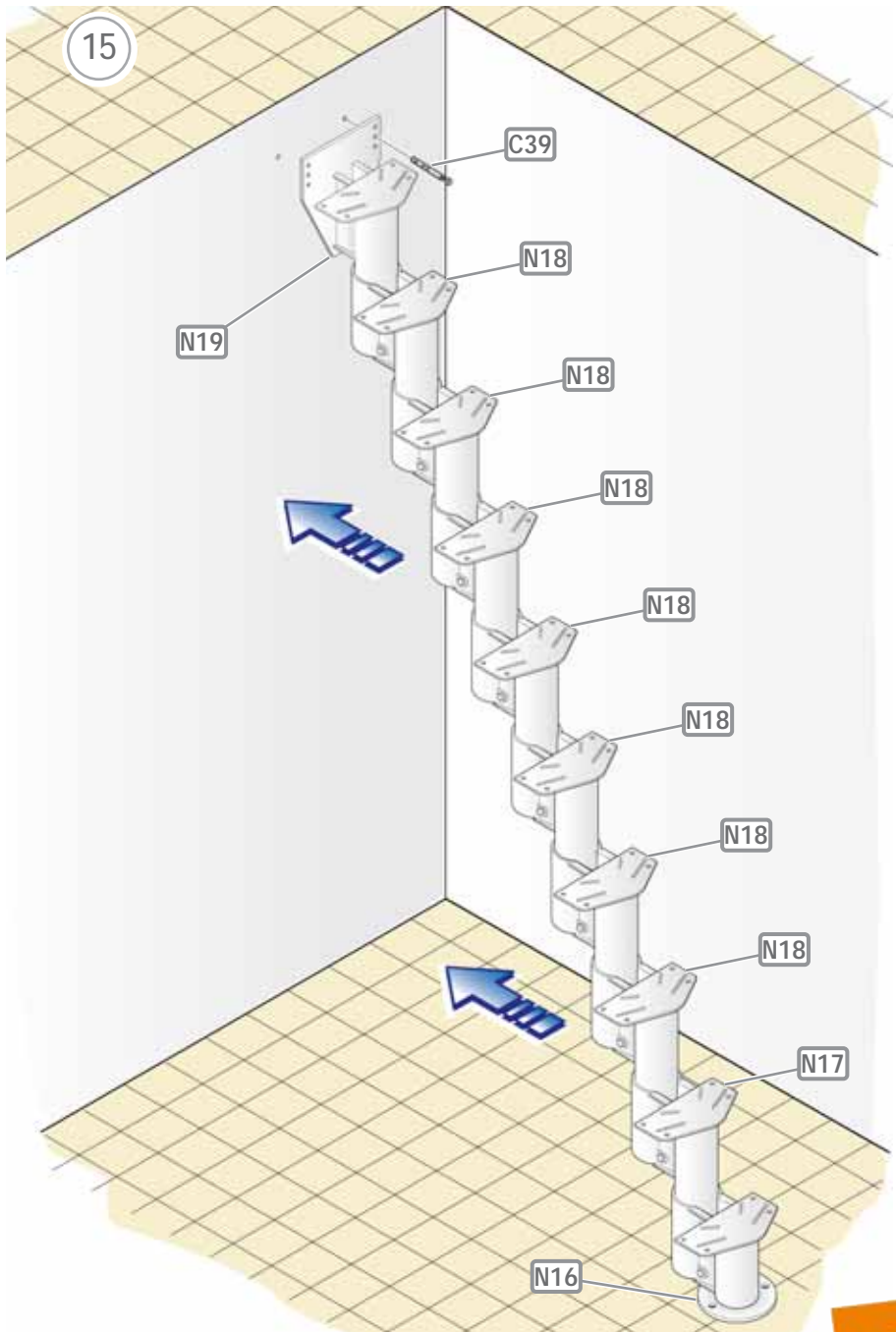

16

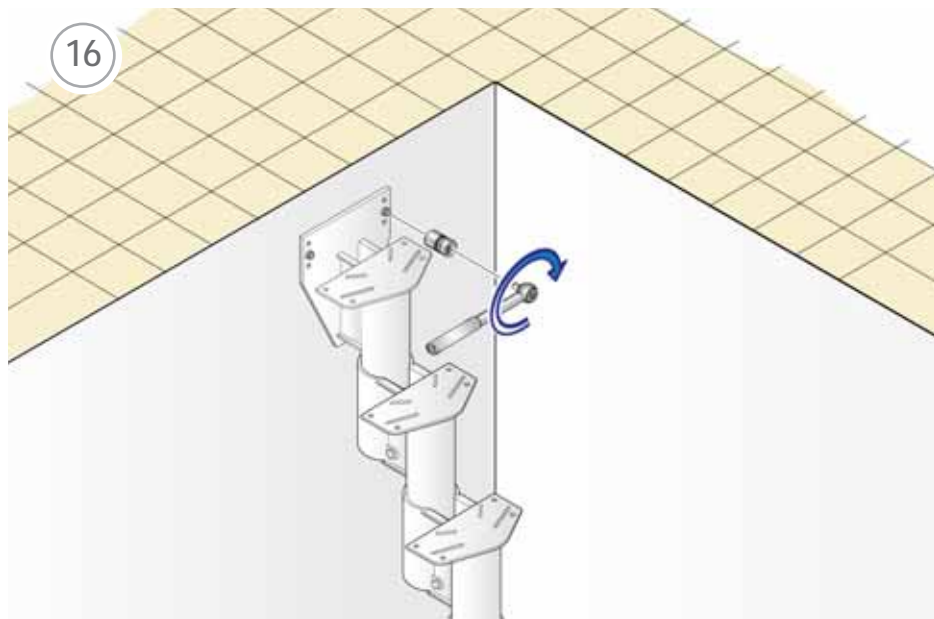

17

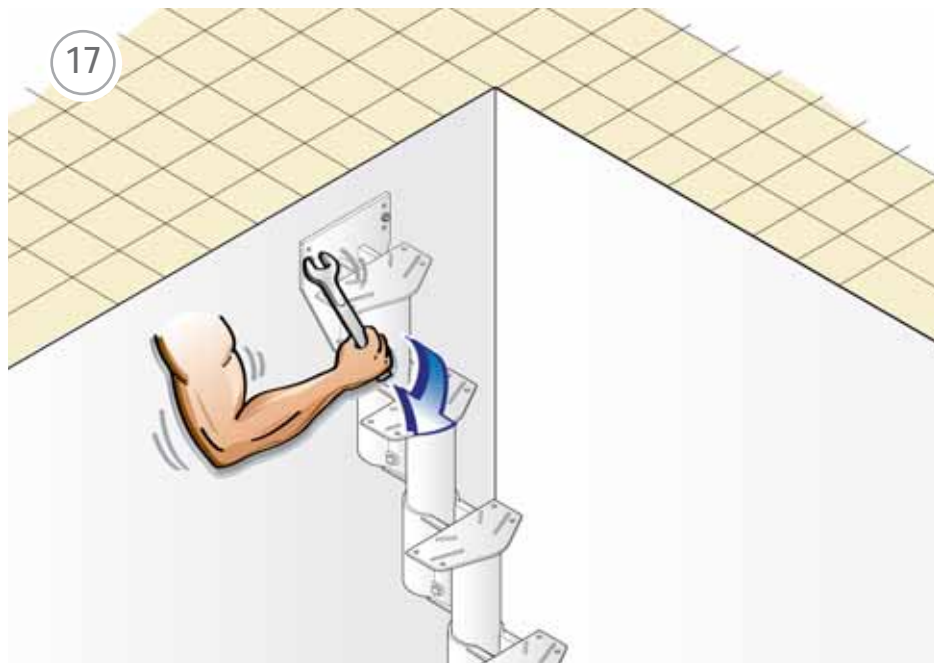

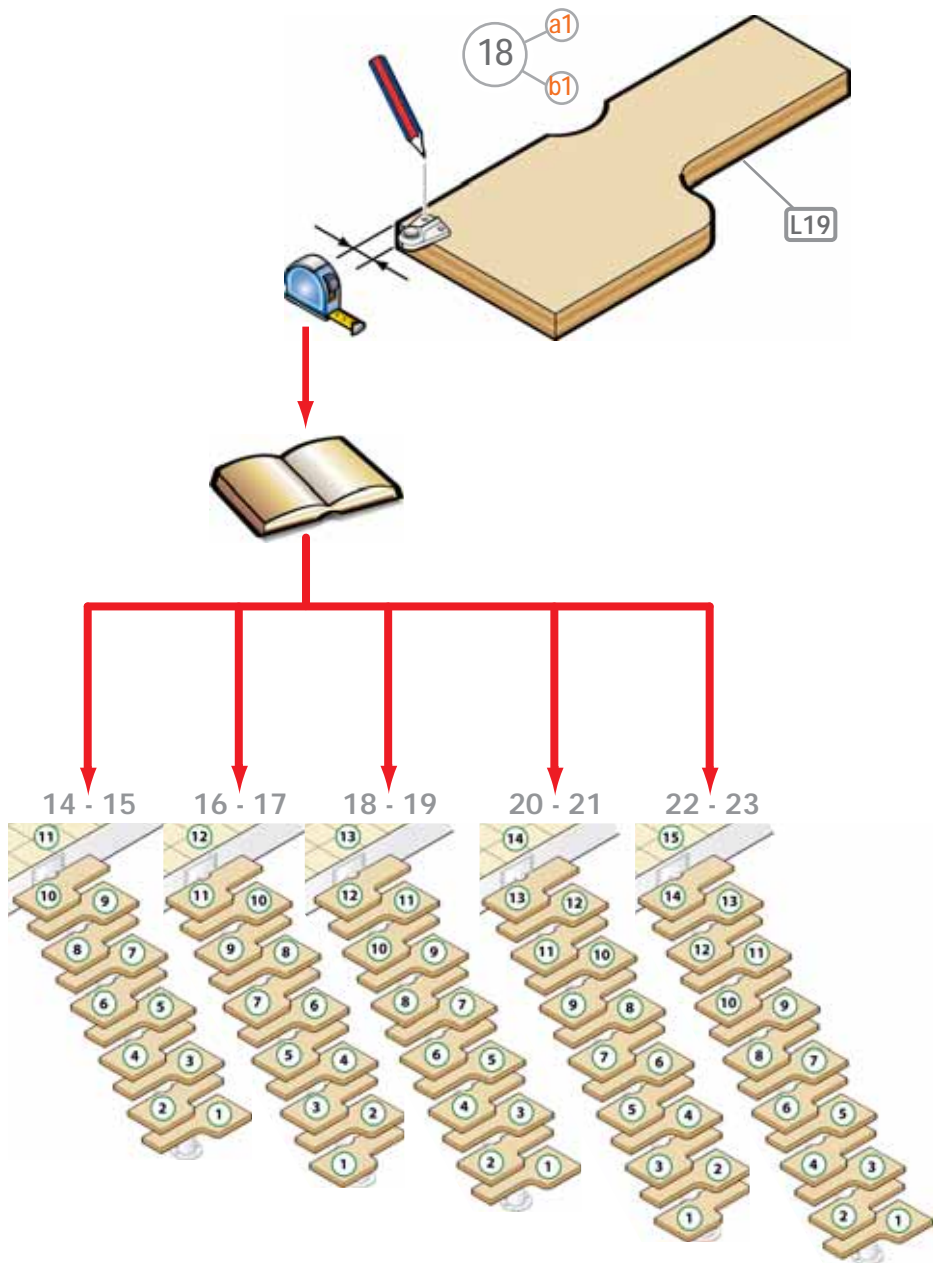

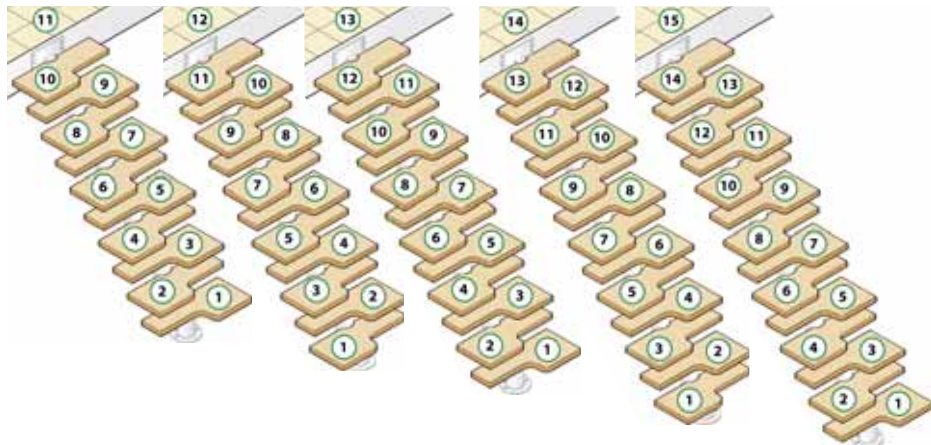
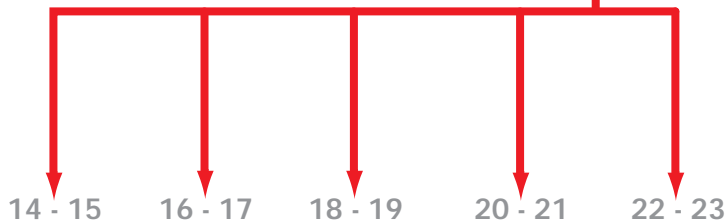
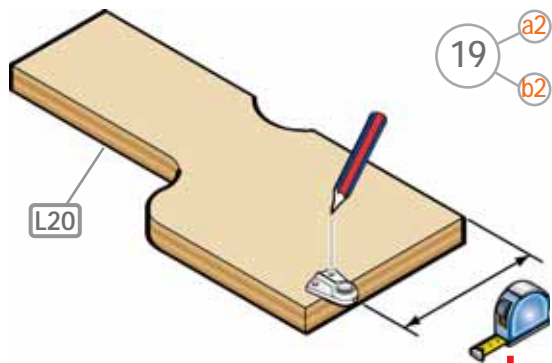

20

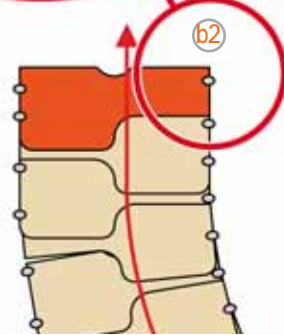
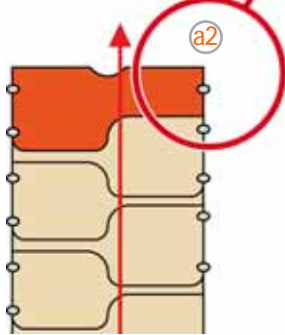
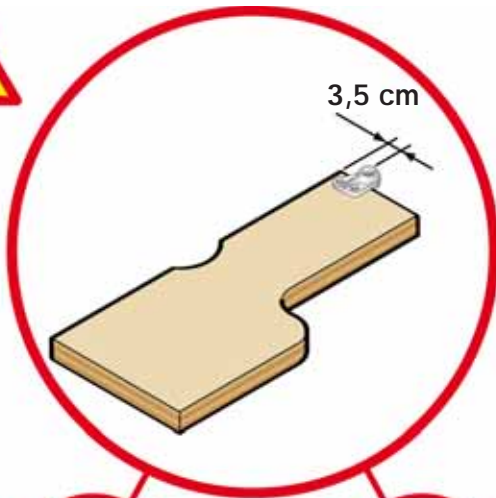



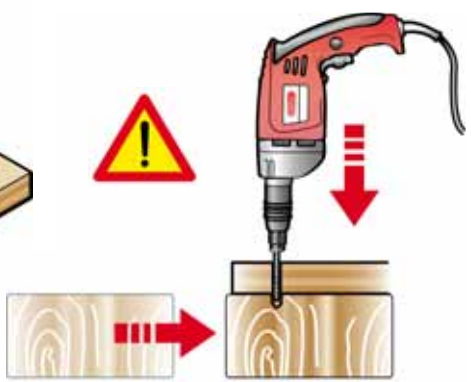
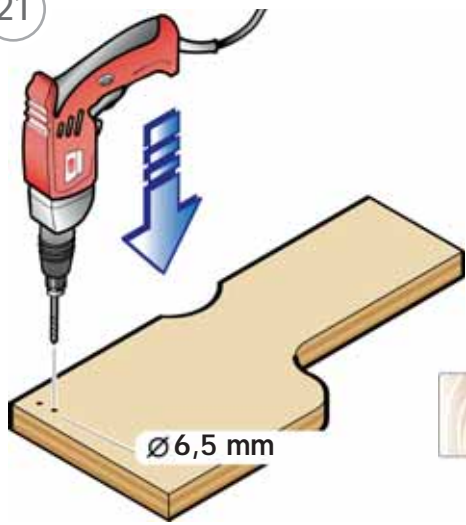

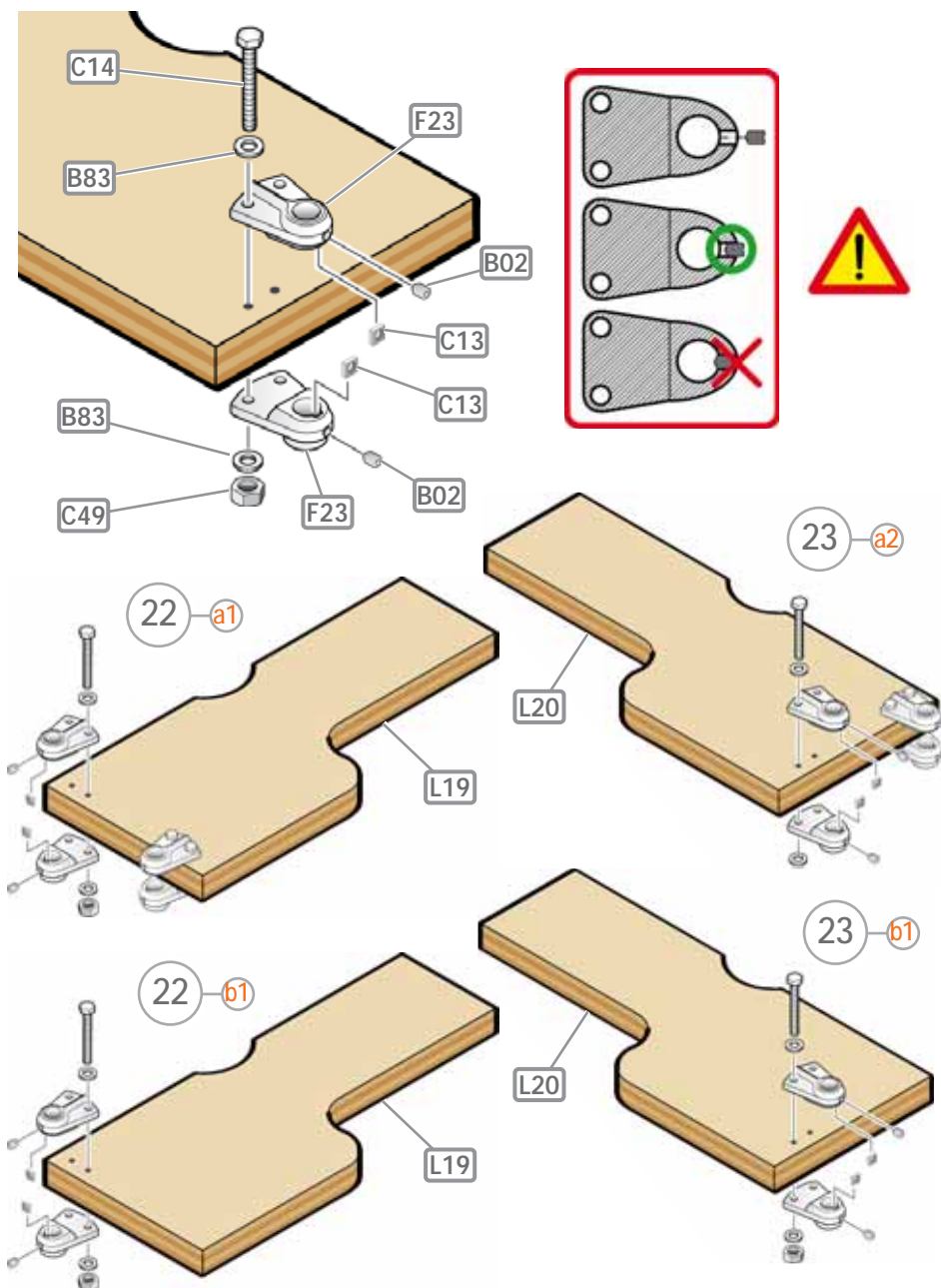

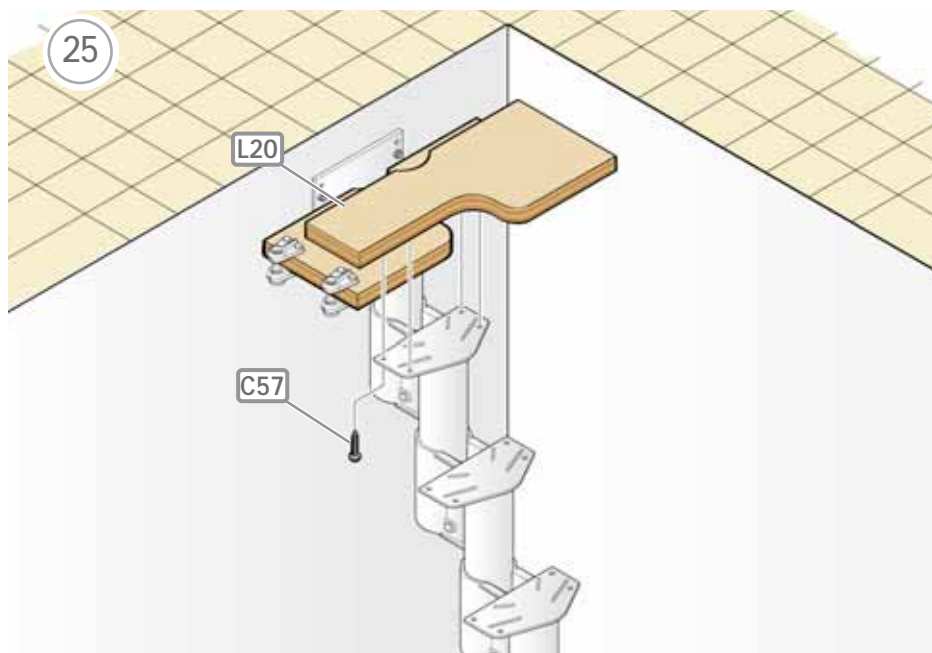
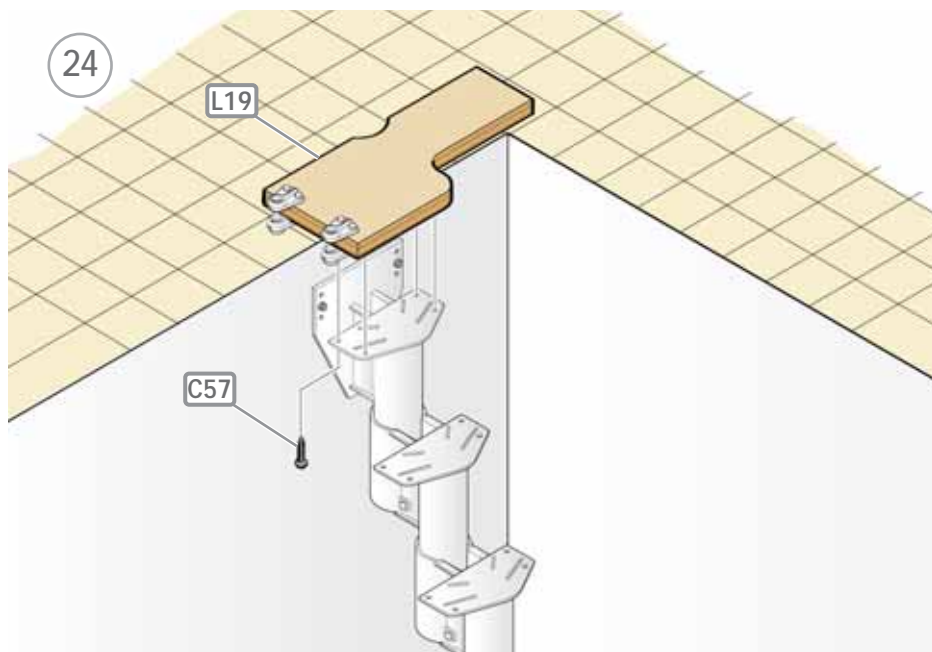

21



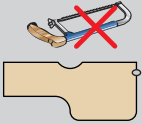

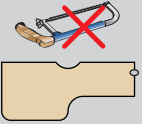



| a1   | a2   | b1   | b2   |
|--|--|--|--|
| D = 98 cm<br> | <del></del>   | D = 98 cm<br> | <del></del>   |
| <del></del>   | D = 88 cm<br> | <del></del>   | D = 92 cm<br> |

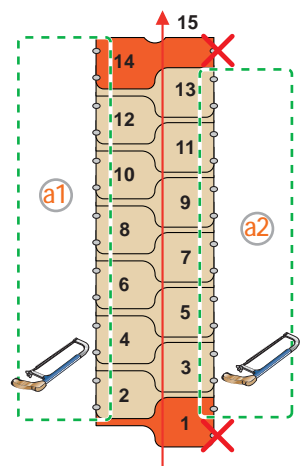
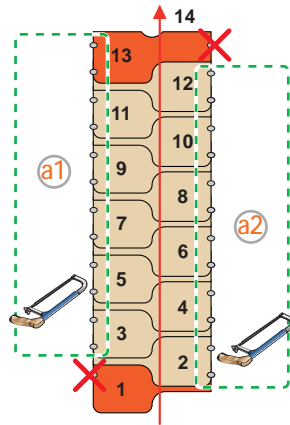
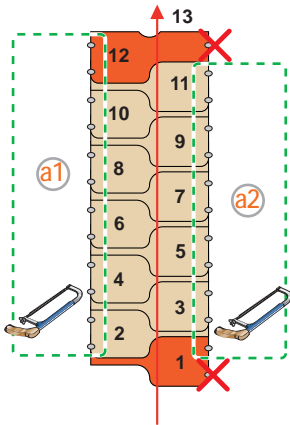
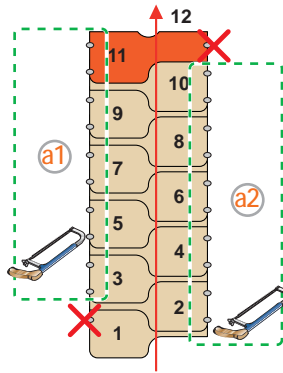
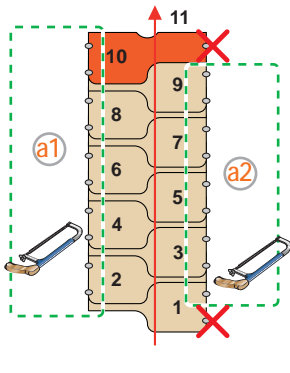
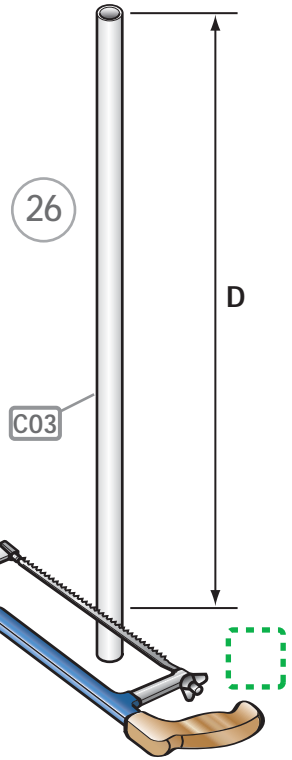

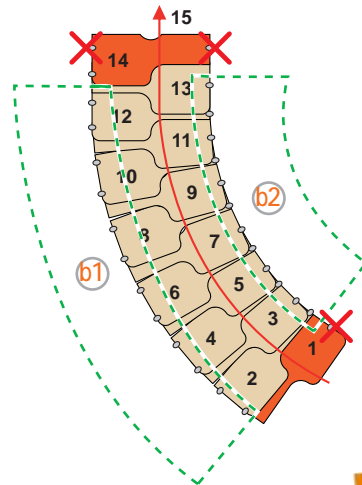
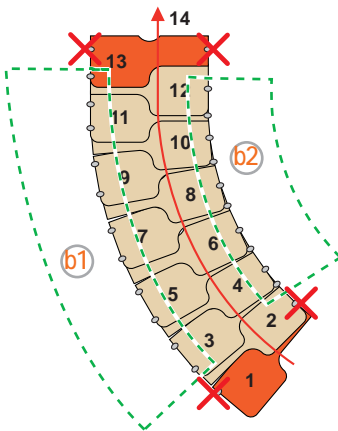
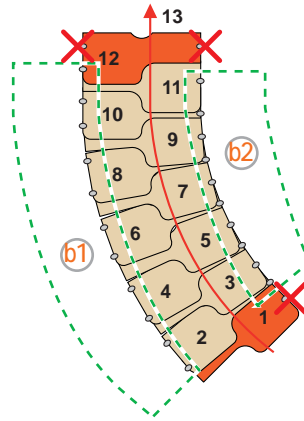
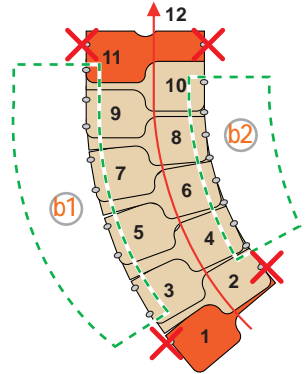
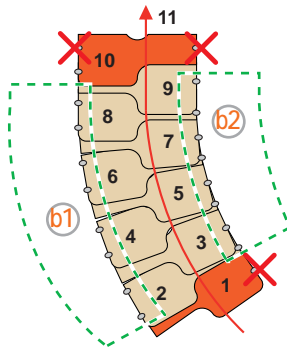
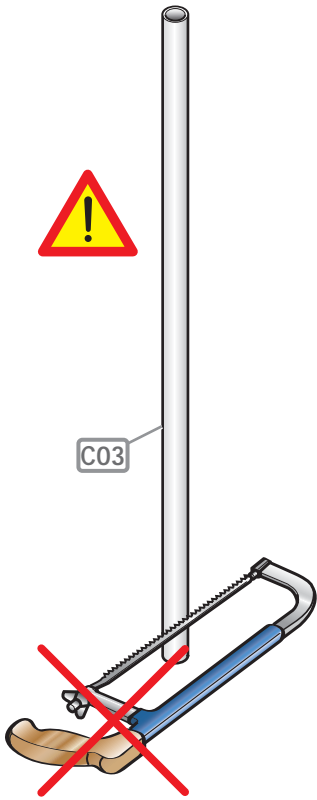

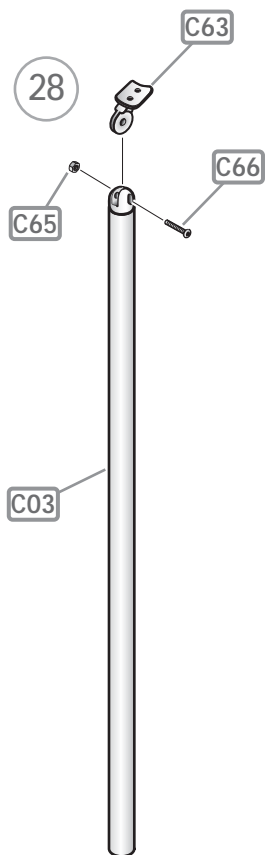
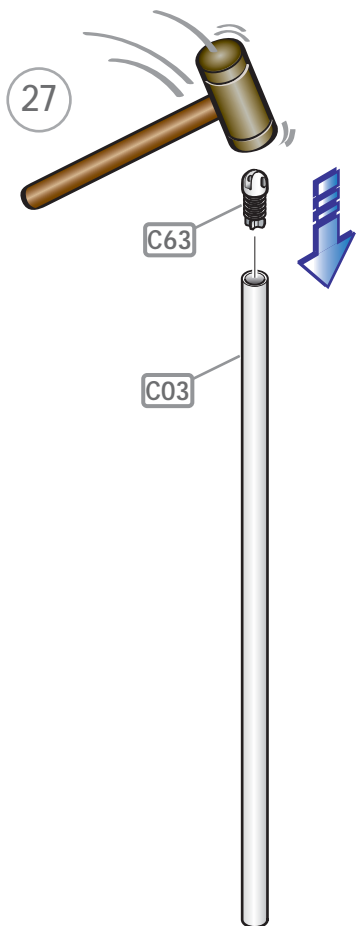

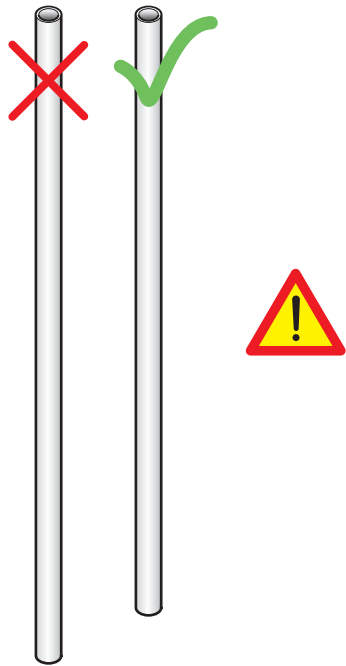
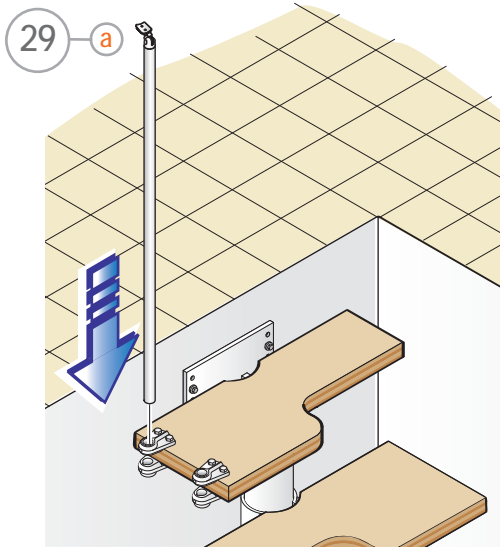

30 a

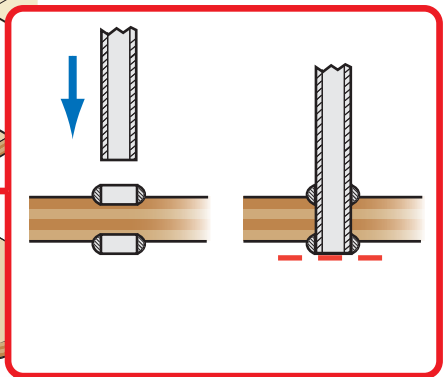
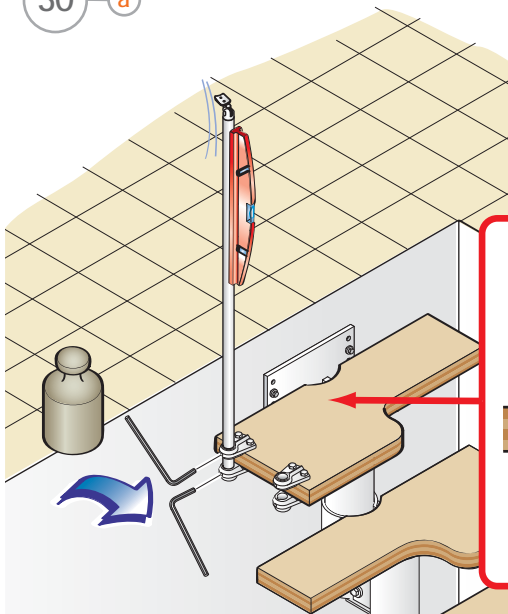

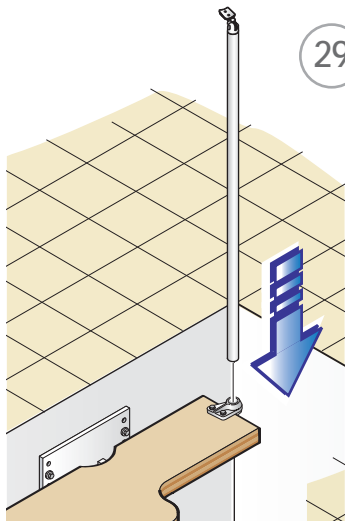
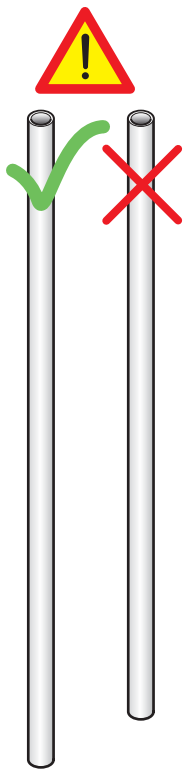

29 (b)

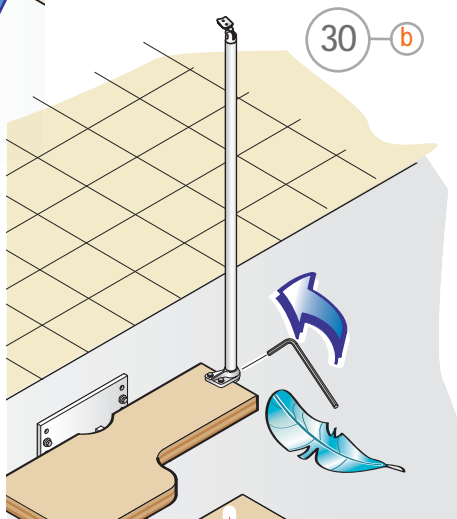

30 (b)

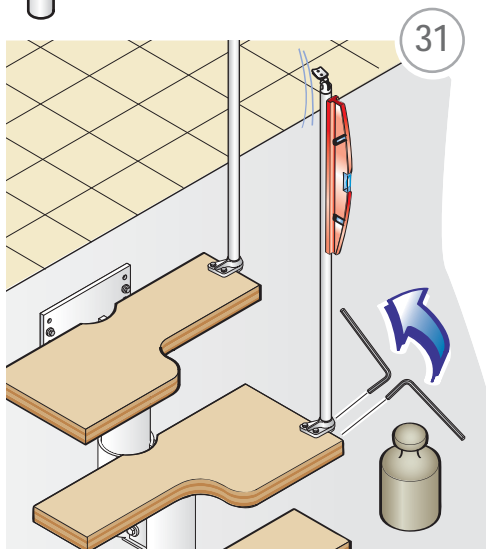

31

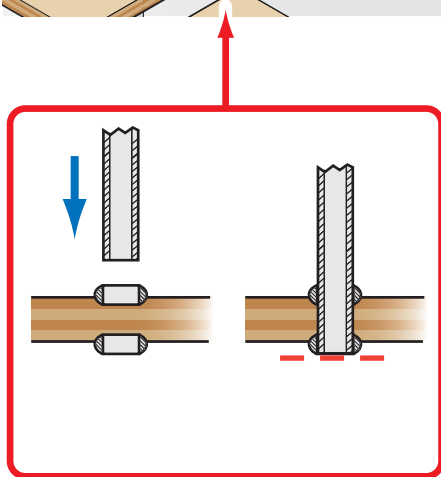

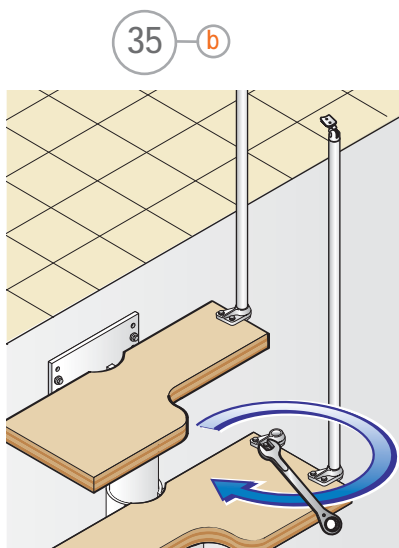
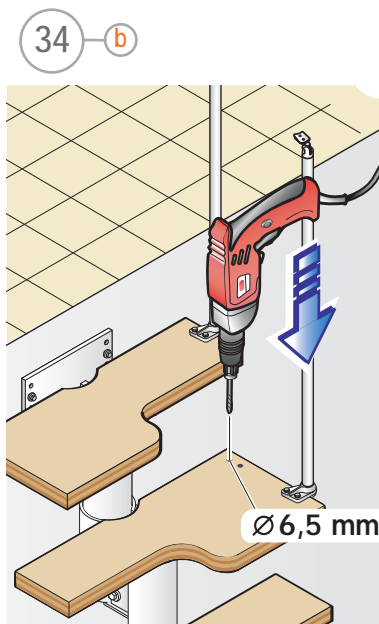
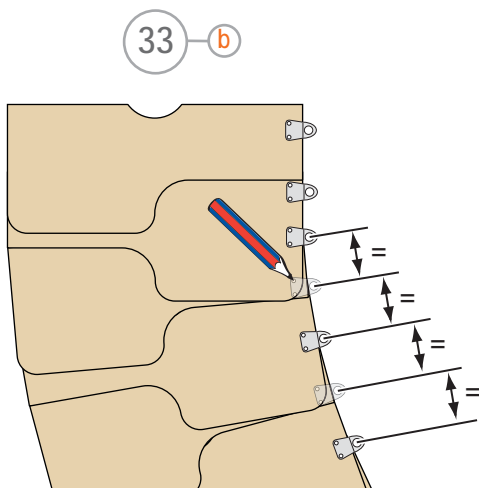
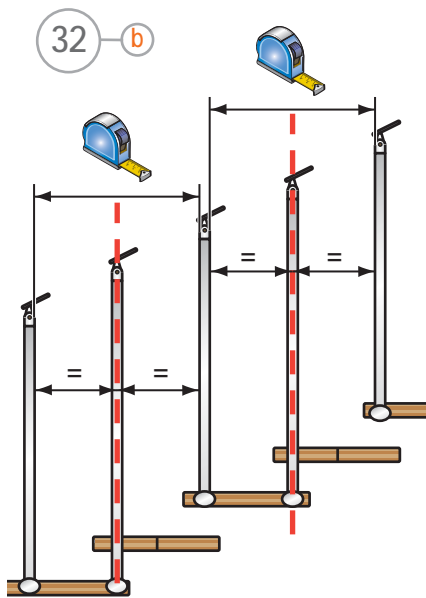

36

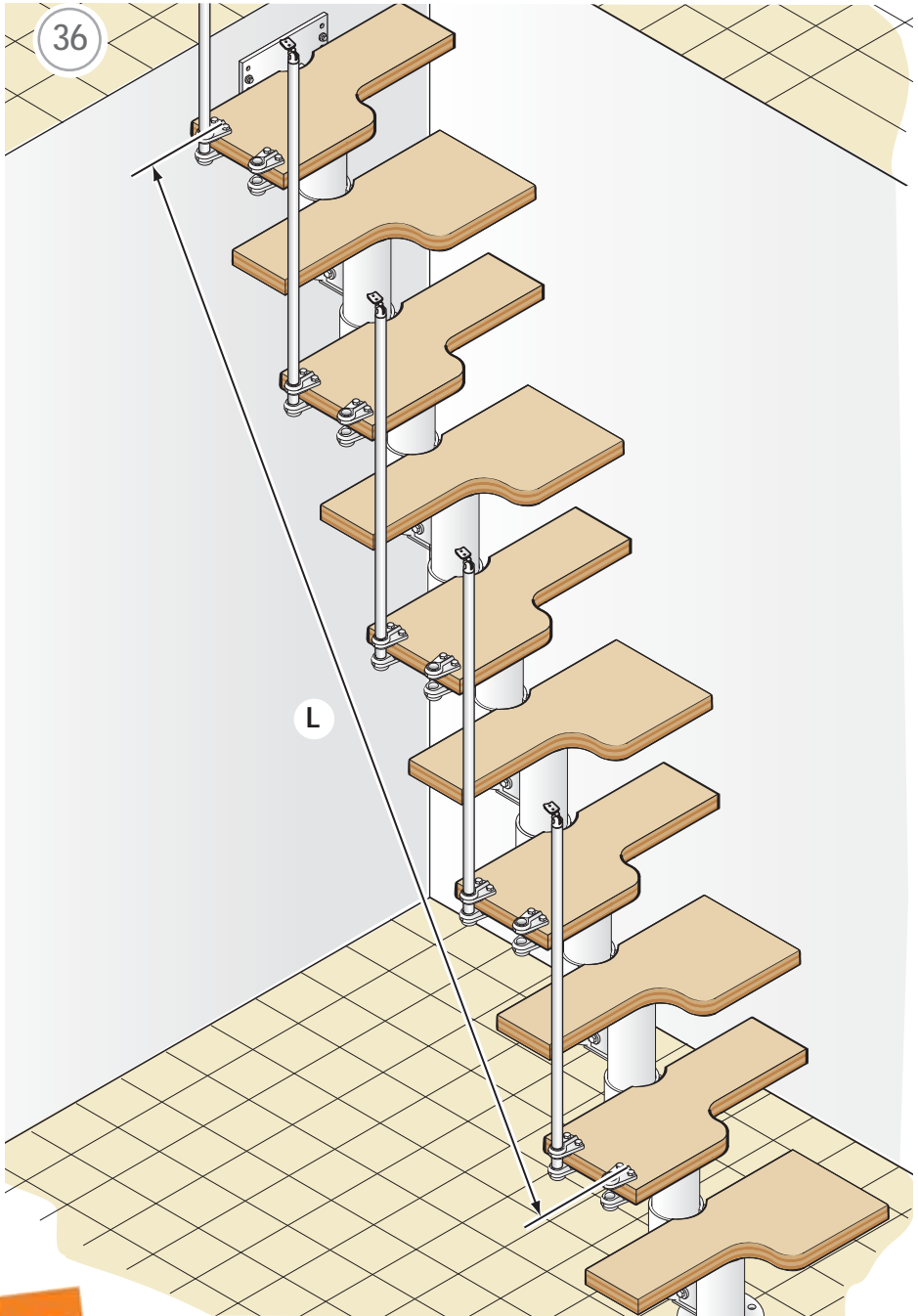



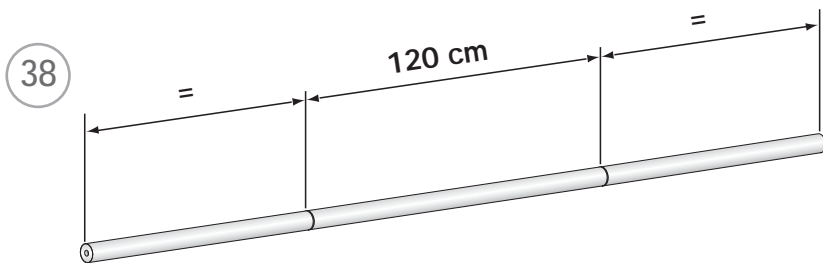
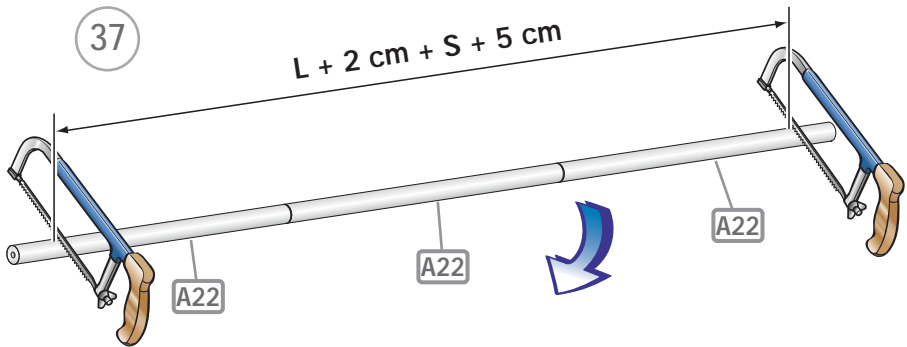
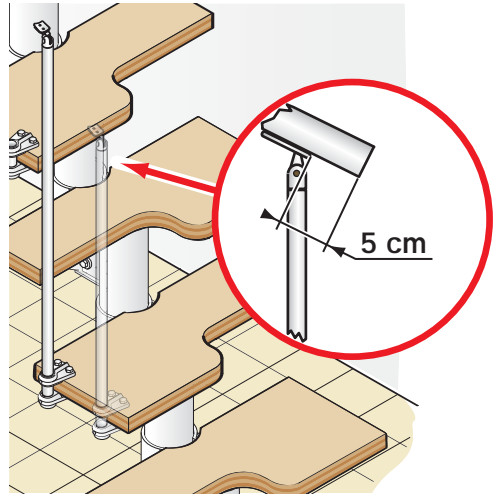
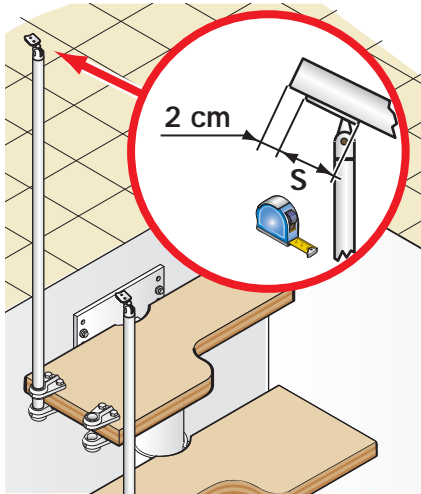

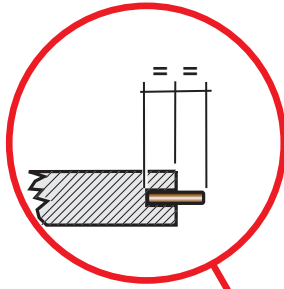

39

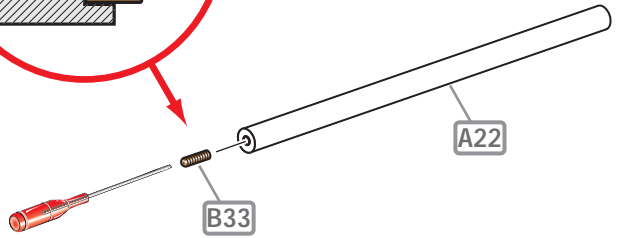

40

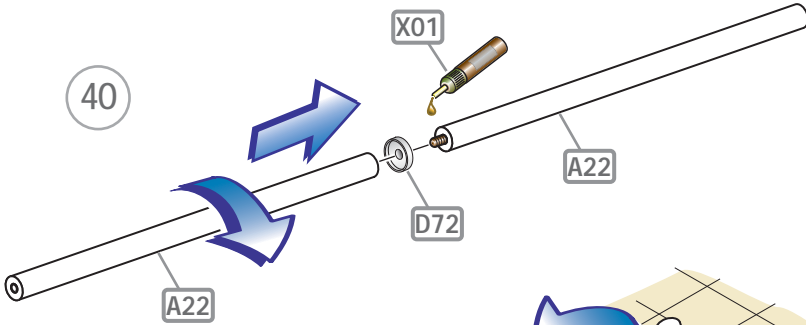

41

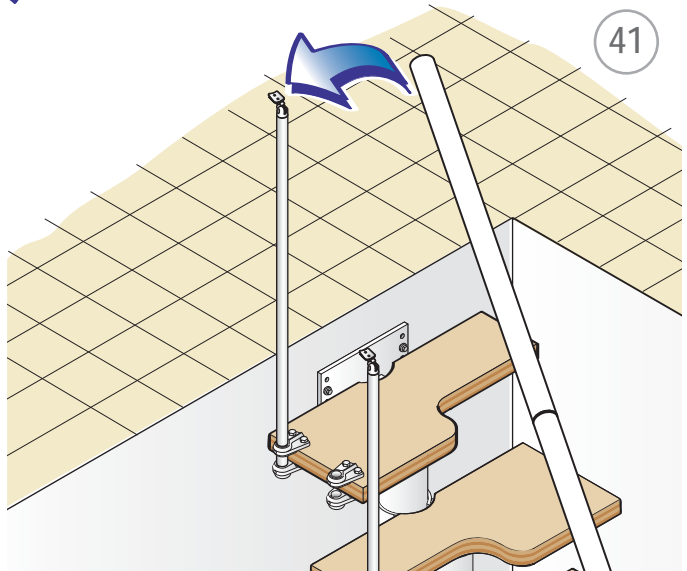

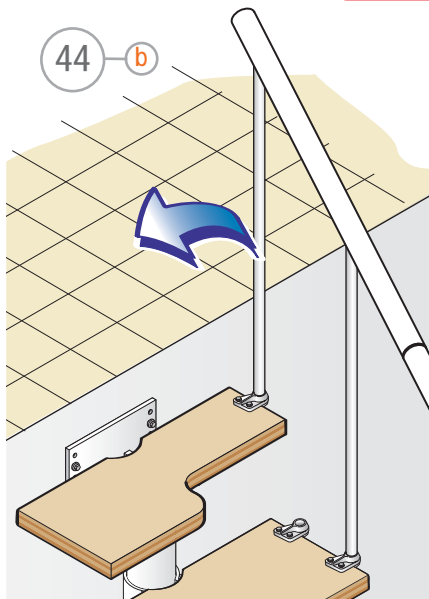
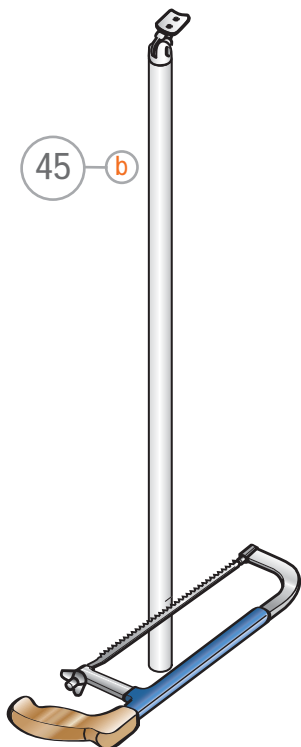
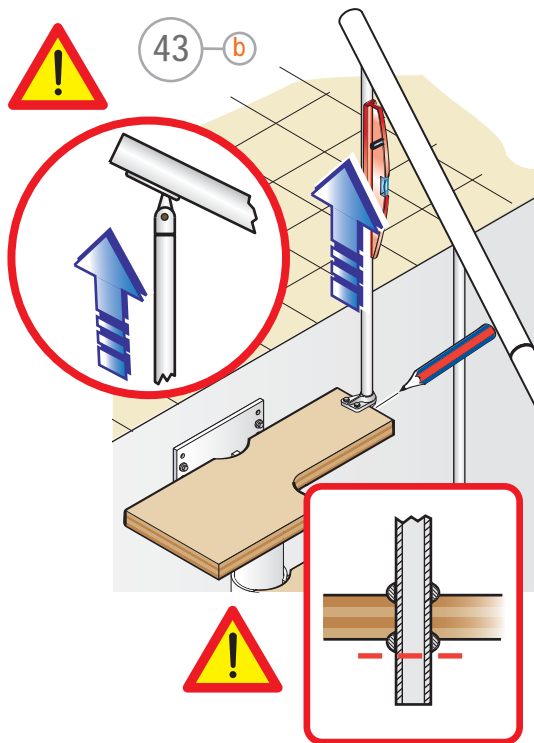
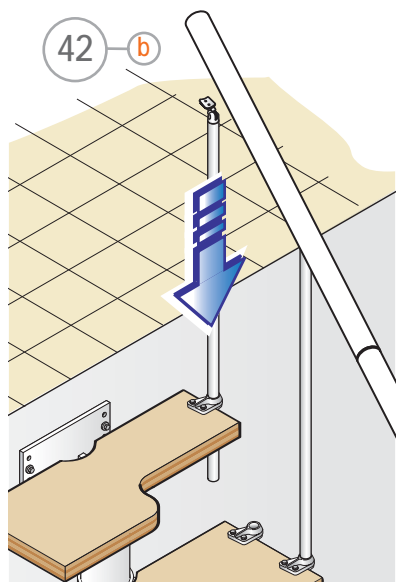

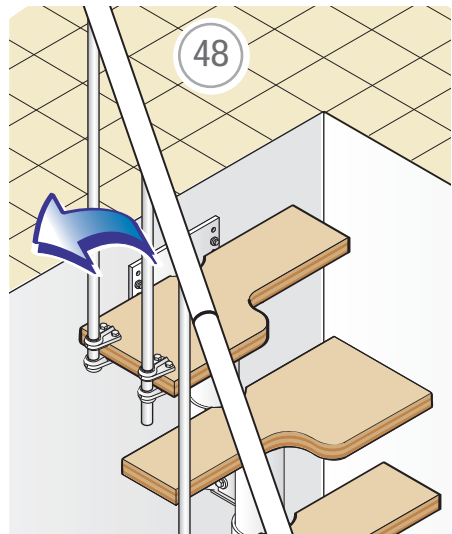
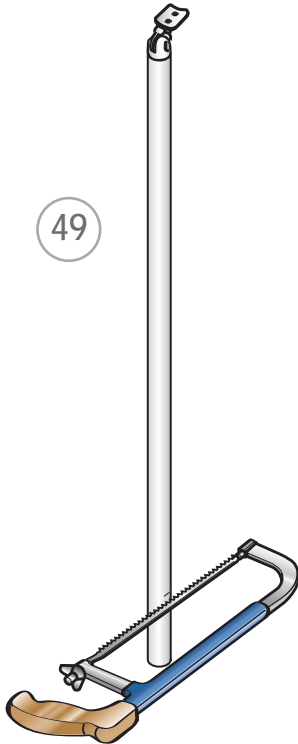
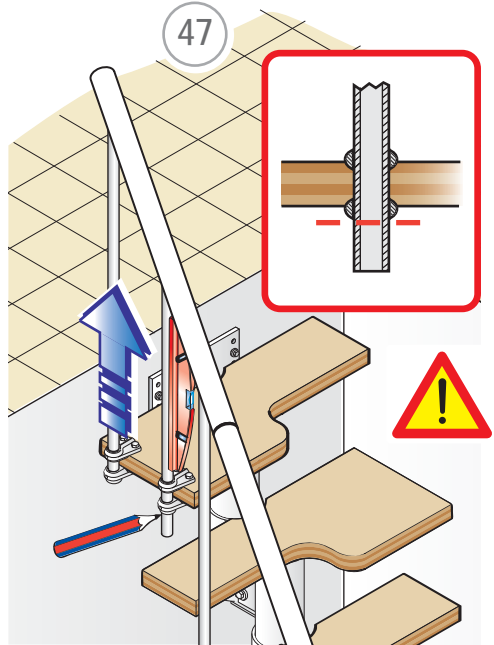
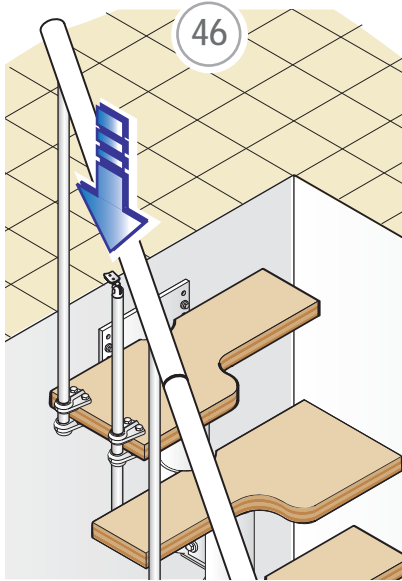

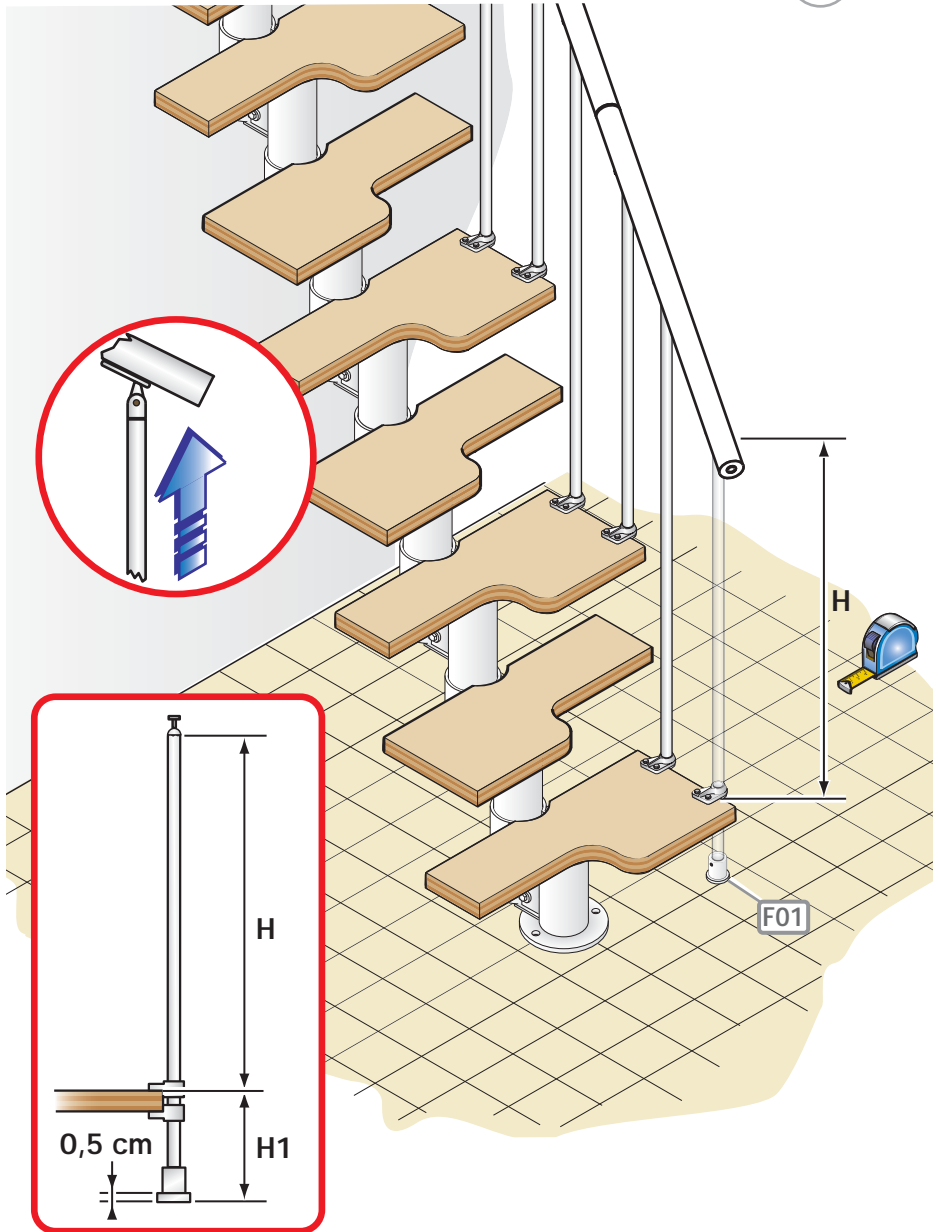

51 b

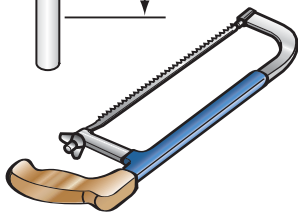
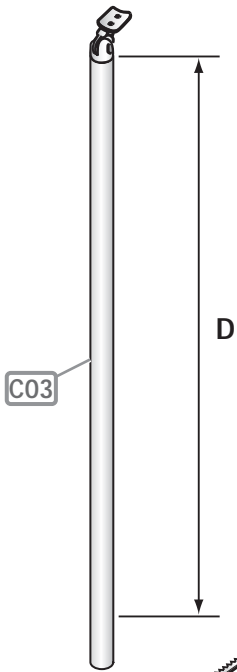

$$D = H + H1 - 0,5 \text{ cm}$$

52 b

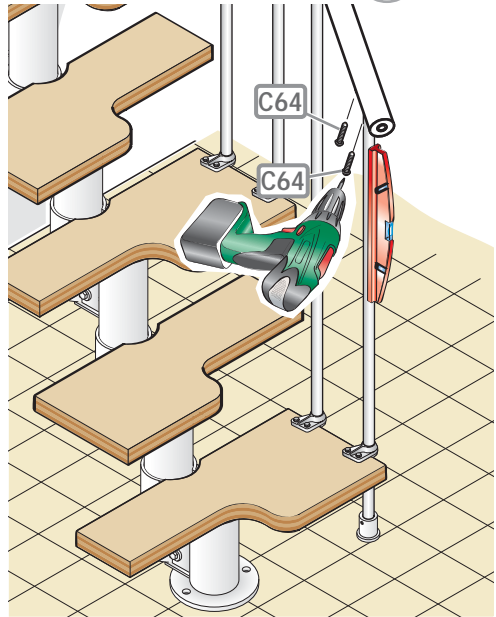

53

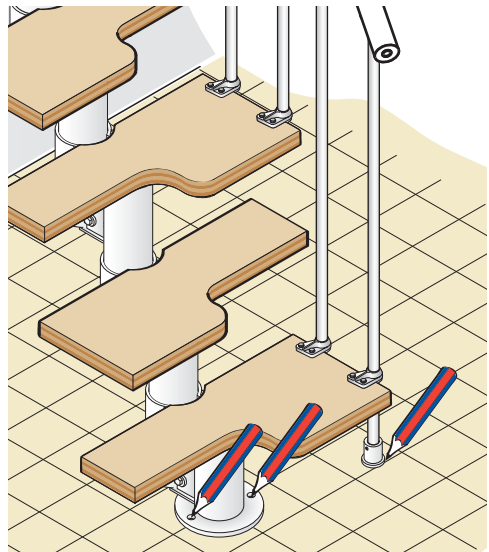

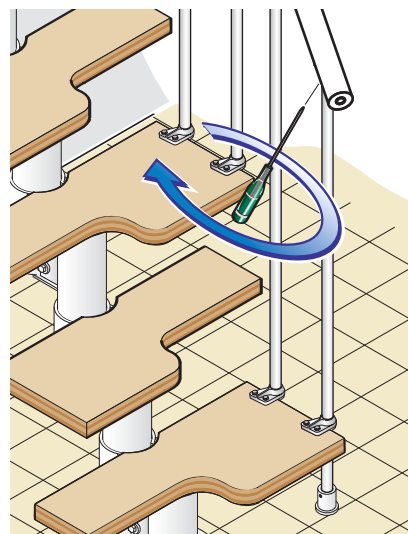
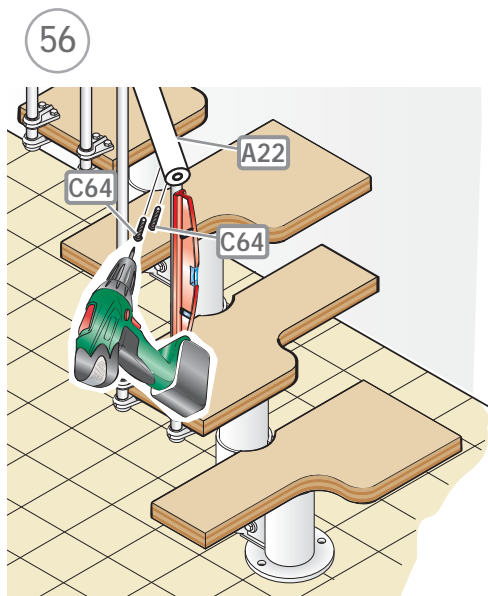
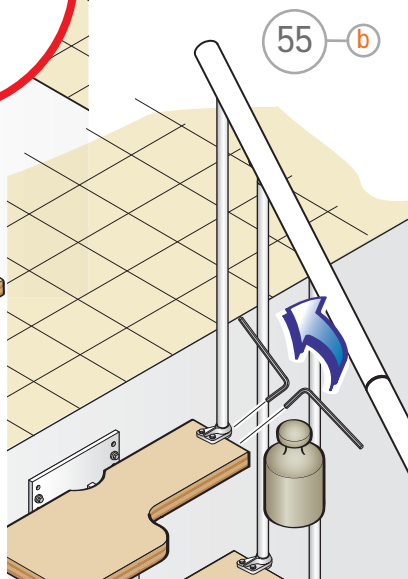
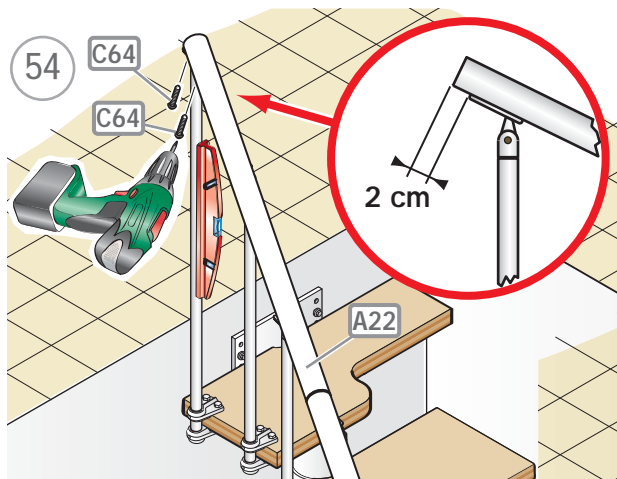

58 b

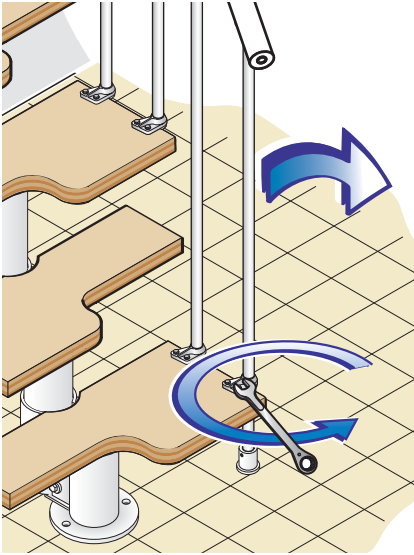

59

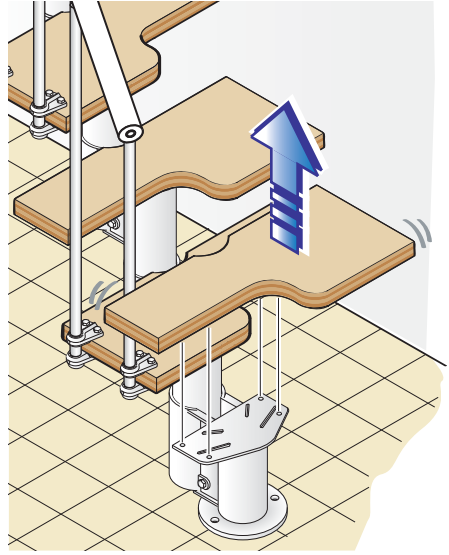

60

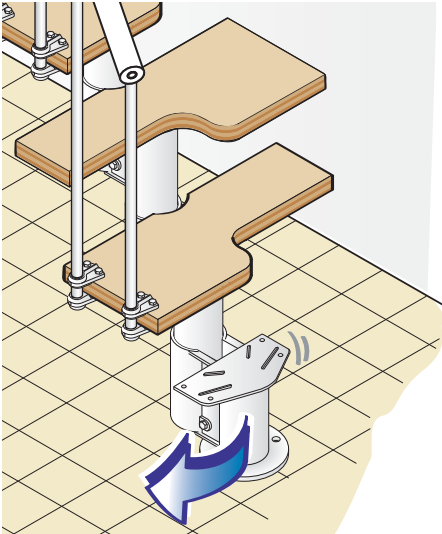

61

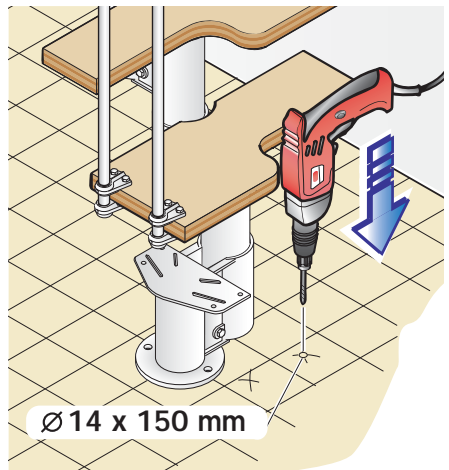



62 b

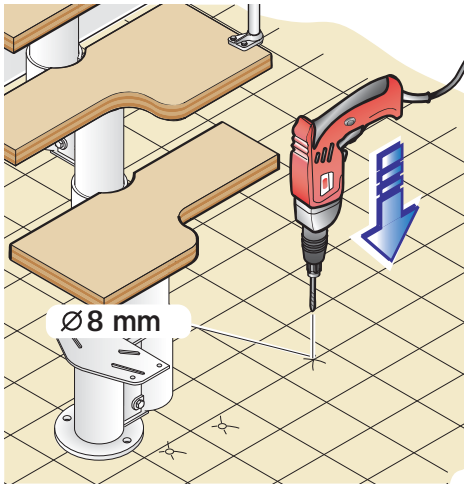

63

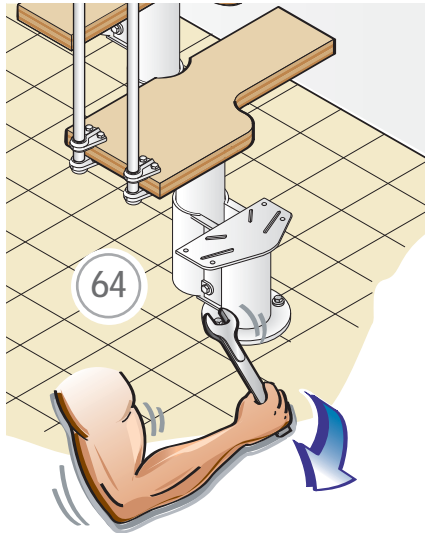
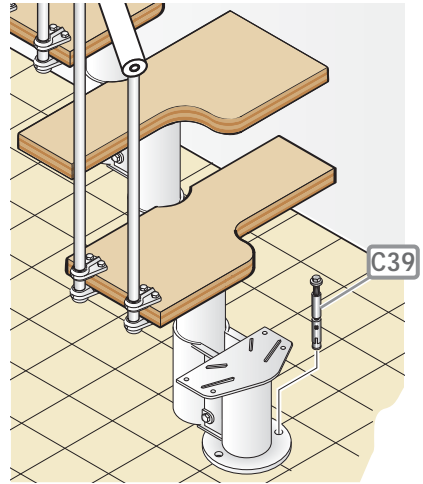

65 b

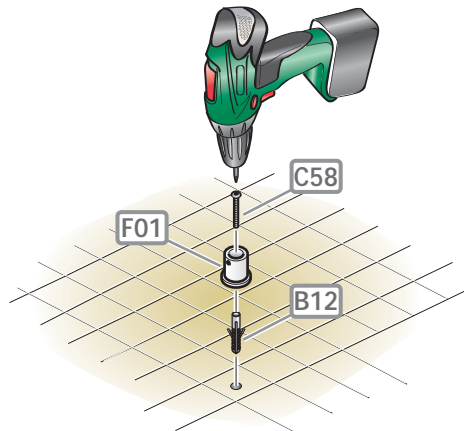

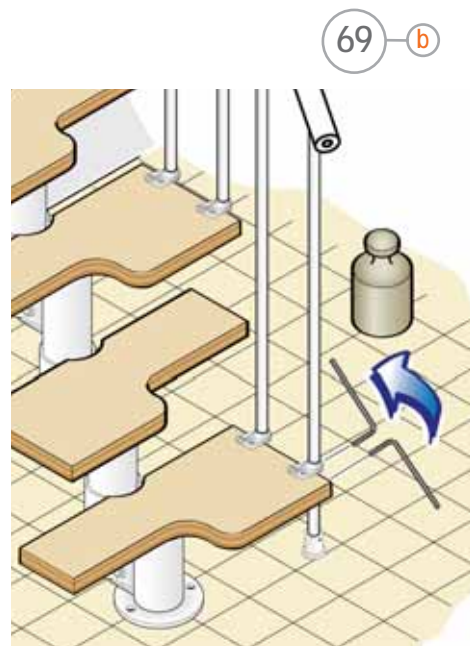
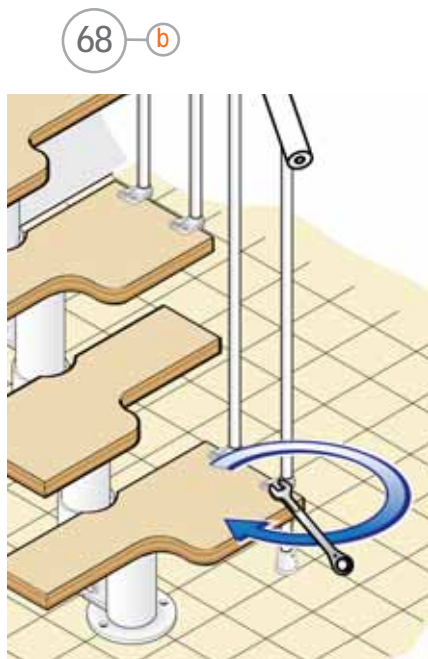
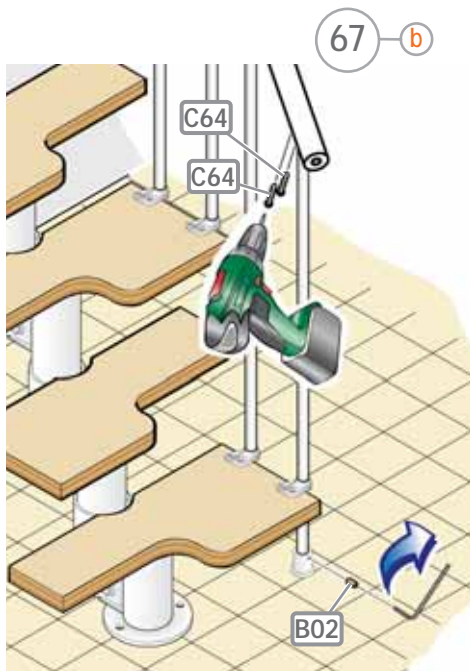
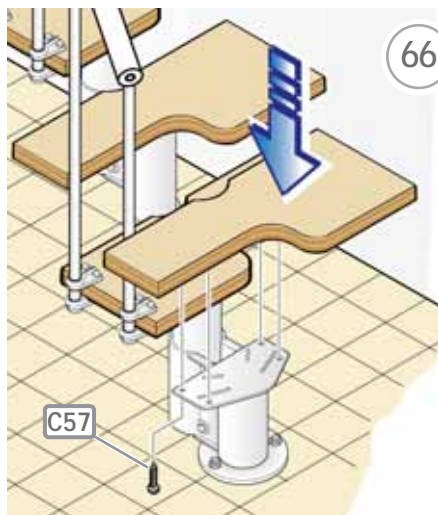

70

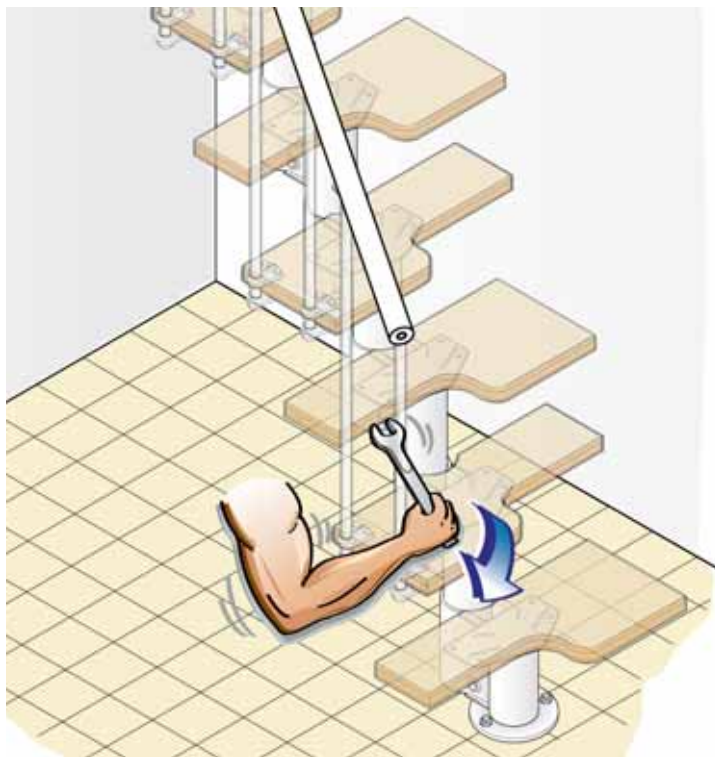

71

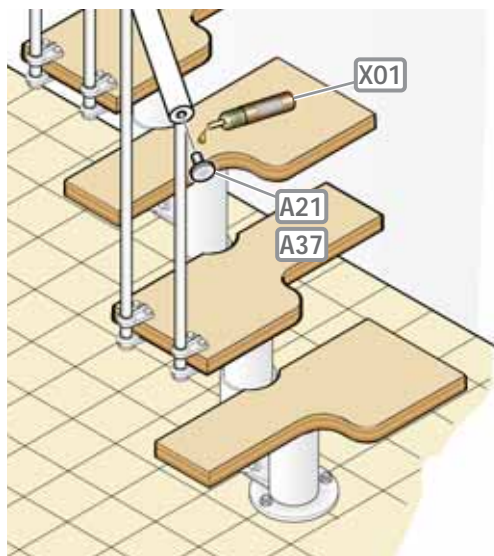

72

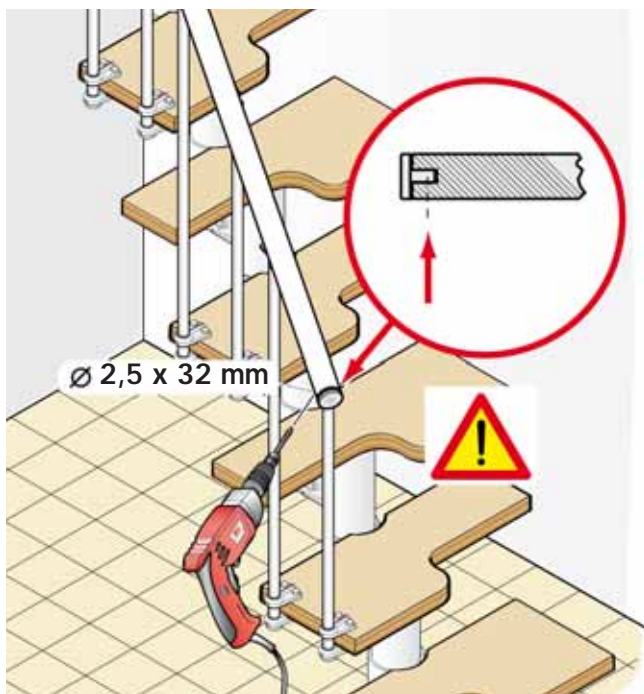

73

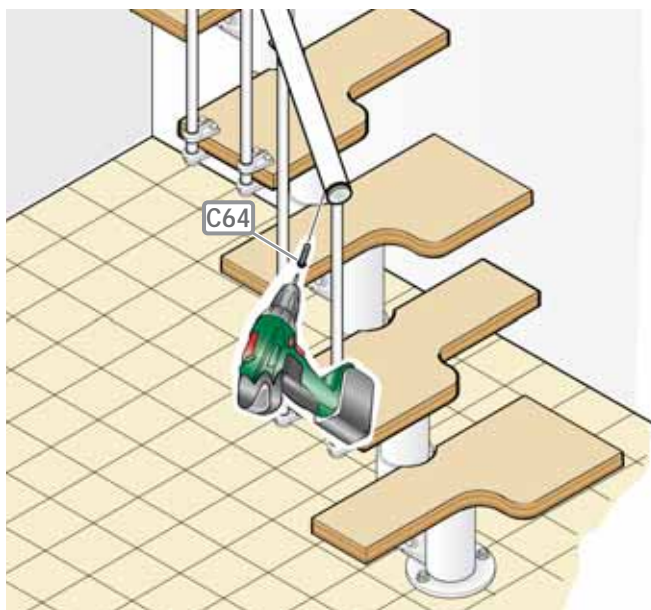

74

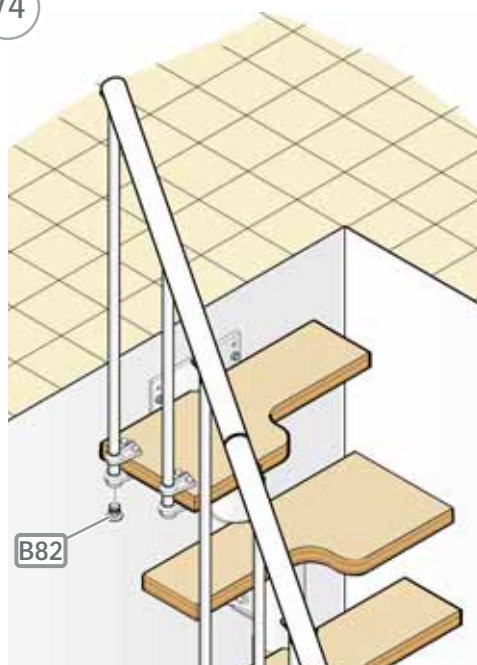

75

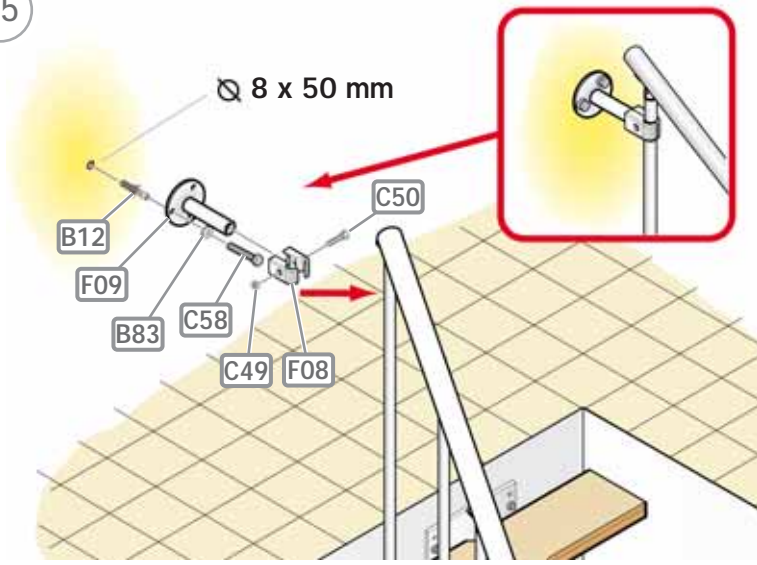

76

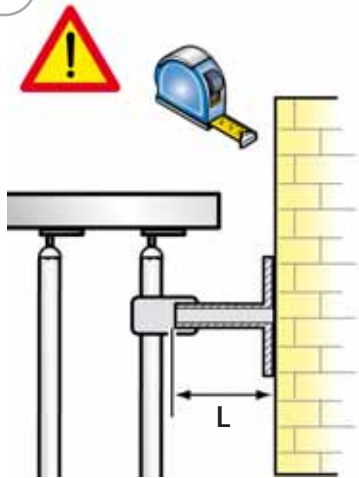

77

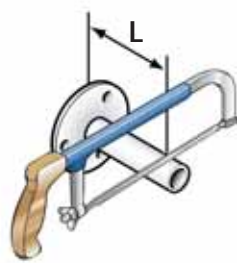



**Italiano**  
**English**  
**Deutsch**  
**Français**  
**Español**

DATI IDENTIFICATIVI DEL PRODOTTO  
PRODUCT DETAILS  
PRODUKTEIGENSCHAFTEN  
DONNÉES D'IDENTIFICATION DU PRODUIT  
DATOS DE IDENTIFICACIÓN



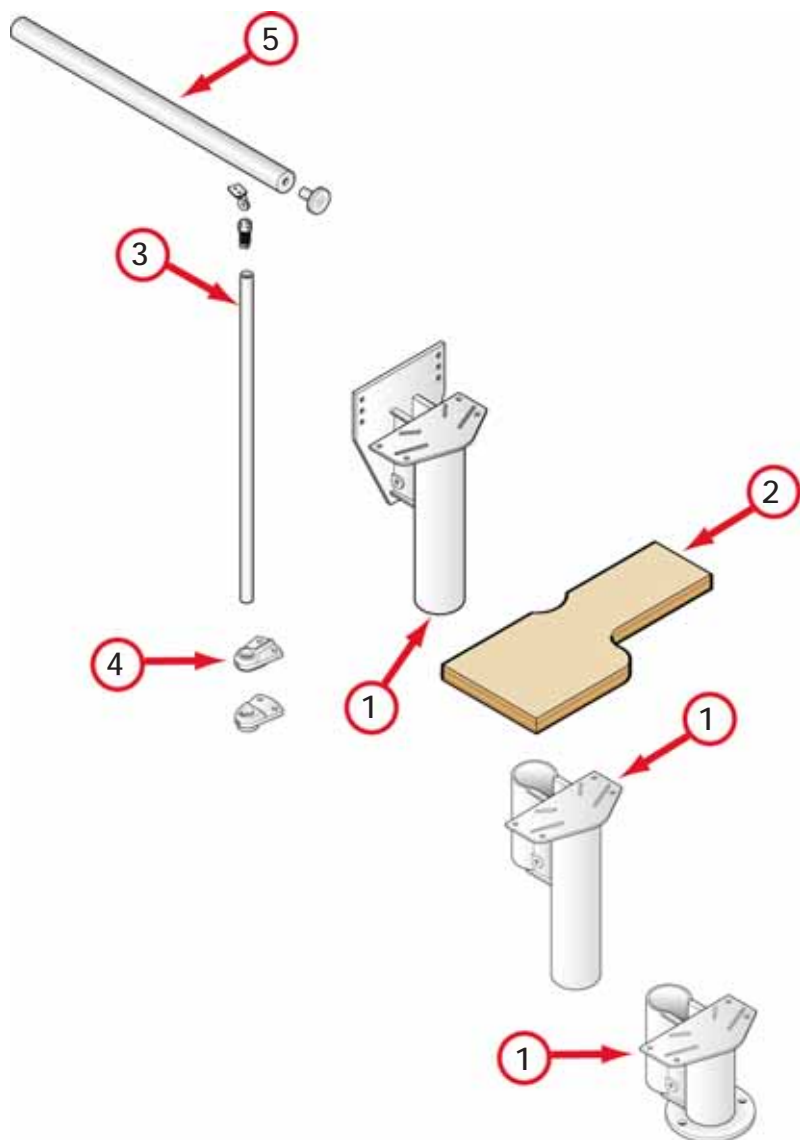



I)

## **dati identificativi del prodotto**

denominazione commerciale: **MAGIA 30**

tipologia: scala a giorno con gradini sfalsati e rotazione delle rampe con pendenza

### **materiali impiegati**

#### **STRUTTURA**

##### **descrizione**

composta da elementi (1) metallici assemblati fra di loro con bulloni

##### **materiali**

Fe 370

##### **finitura**

verniciatura a forno con polveri epossidiche

#### **GRADINI**

##### **descrizione**

gradini (2) in legno sagomati assemblati alla struttura con bulloni

##### **materiali**

multistrato di betulla

##### **finitura**

tinta: all'acqua

fondo: poliuretano

finitura: poliuretano

#### **RINGHIERA**

##### **descrizione**

composta da colonnine (3) verticali in metallo fissate ai gradini (2) e da corrimano (5) in PVC

##### **materiali**

colonnine (3): Fe 370

fissaggi (4): nylon

corrimano (5): PVC con anima di alluminio

##### **finitura**

colonnine (3): verniciatura a forno con polveri epossidiche

#### **PULIZIA**

pulire con panno morbido inumidito in acqua, privo di qualsiasi prodotto contenente solventi o materiali abrasivi.

#### **MANUTENZIONE**

dopo circa 12 mesi dalla data di installazione, controllare il serraggio della viteria dei vari componenti. la manutenzione straordinaria deve essere eseguita a regola d'arte.

#### **PRECAUZIONI D'USO**

evitare usi impropri e non consono al prodotto. eventuali manomissioni o installazioni non rispondenti alle istruzioni del produttore possono inficiare le conformità prestabilite del prodotto.

GB)

## **product details**

trade name: **MAGIA 30**

type: flight staircase with alternate treads and flight rotation with slope

### **used materials**

#### **STRUCTURE**

##### **description**

composed of metallic elements (1) assembled between themselves by bolts

##### **materials**

spacers: Fe 370

##### **finishing**

oven varnishing with epoxy powders

#### **TREADS**

##### **description**

wooden shaped treads (2) assembled to the structure by bolts

##### **materials**

birch plywood

##### **finishing**

colour: water-base

undercoat: polyurethane

finishing: polyurethane

#### **RAILING**

##### **description**

composed by vertical metal balusters (3) fixed to the treads (2) and by a PVC handrail (5)

##### **materials**

balusters (3): Fe 370

fixings (4): nylon

handrail (5): PVC with aluminium core

##### **finishing**

balusters (3): oven varnishing with epoxy powders

#### **CLEANING**

clean with a soft wet cloth, without any product containing solvents or abrasive materials.

#### **MAINTENANCE**

about 12 months after the installation date, check the tightening of bolts on the various components. all non-routine maintenance procedures must be carried out in a strictly professional manner.

#### **USE PRECAUTION**

avoid any improper use that is not in accordance with the product. possible violations or installations which don't comply with the providers instructions can invalidate the agreed product conformities.

## D)

### Produkteigenschaften

kommerzielle Bezeichnung: **MAGIA 30**

Typologie: Mittelholztreppe mit versetzten Stufen, Wendelung der Treppenläufe mit Neigung

#### verwendete Materialien

#### STRUKTUR

##### Beschreibung

bestehend aus Metallteilen (1) die miteinander durch Bolzen verbunden sind

##### Materialien

Fe 370

##### Ausführung

Pulverbeschichtung mit Epoxidharzen

#### STUFEN

##### Beschreibung

geformte Stufen (2) aus Holz an der Struktur mittels Bolzen befestigt

##### Materialien

Mehrschichtbirkenholz

##### Ausführung

Beizung: Wasserfarbe

Grundierung: Polyurethan

Oberlack: Polyurethan

#### GELÄNDER

##### Beschreibung

bestehend aus senkrechten Geländerstäben (3) aus Metall, die an den Stufen (2) befestigt sind, und einem Handlauf (5) aus PVC

##### Materialien

Geländerstäbe (3): Fe 370

Befestigungen (4): Nylon

Handlauf (5): PVC mit Aluminiumkern

##### Ausführung

Geländerstäbe (3): Pulverbeschichtung mit Epoxidharzen

#### REINIGUNG

mit einem weichen feuchten Tuch reinigen. keine Reinigungsmittel verwenden, die Lösungs- oder Scheuermittel beinhalten.

#### WARTUNG

ungefähr 12 Monate nach dem Einbau, die Festigkeit der einzelnen Schrauben überprüfen. die außerordentliche Wartung muss nach allen Regeln der Kunst ausgeführt werden.

#### VORSICHTSMAßNAHMEN FÜR DIE ANWENDUNG

die falsche und unangemessene Verwendung des Produkts vermeiden. eventuelle Beschädigungen oder nicht der Montageanleitung des Herstellers gemäße Einrichtungen können die vorgegebene Produktkonformität für ungültig erklären.

## F)

### données d'identification du produit

denomination commerciale: **MAGIA 30**

typologie: escalier à volée avec marches décalées et rotation des volées en pente

#### matériaux utilisés

#### STRUCTURE

##### description

composée d'éléments (1) métalliques assemblés entre eux par boulonnage

##### matériaux

Fe 370

##### finition

vernissage à chaud avec poudres époxy

#### MARCHES

##### description

marches façonnées (2) en hêtre massif assemblées à la structure par boulonnage

##### matériaux

multipli de bouleau

##### finition

verniss: à l'eau

mordant: polyuréthanique

finition: polyuréthanique

#### GARDE-CORPS

##### description

composé de colonnettes (3) verticales en métal fixées aux marches (2) et d'une main courante (5) en PVC

##### matériaux

colonnettes (3): Fe 370

fixations (4): nylon

main courante (5): PVC avec noyau en aluminium

##### finition

colonnettes (3): vernissage à chaud avec poudres époxy

#### NETTOYAGE

nettoyer avec un chiffon souplé humidifié à l'eau, sans aucun produit contenant des solvants ou matières abrasives.

#### ENTRETIEN

après environ 12 mois de la date d'installation, contrôler le serrage de la visserie et des différents éléments. l'entretien extraordinaire doit être exécuté dans les règles de l'art.

#### PRECAUTION D'UTILISATION

éviter l'utilisation impropre et non conforme au produit. d'éventuelles alterations ou installations non correspondantes aux instructions du producteur peuvent invalider les conformités préétablies du produit.



## E)

### datos de identificación del producto

denominación comercial: **MAGIA 30**

tipo: escalera abierta con peldaños de paso alternado y rotación de los tramos con pendiente

### materiales empleados

#### ESTRUCTURA

##### descripción

compuesta por elementos (1) metálicos ensamblados entre ellos mediante pernos

##### materiales

Fe 370

##### acabado

barnizado en horno con polvos epoxídicos

#### PELDAÑOS

##### descripción

peldaños (2) de madera perfilados y ensamblados a la estructura mediante pernos

##### materiales

multicapa de abedul

##### acabado

barniz: al agua

imprimación: poliuretánica

acabado: poliuretánico

#### BARANDILLA

##### descripción

compuesta por barrotes (3) verticales de metal fijados a los peldaños (2) y por un pasamanos (5) de PVC

##### materiales

barrotes (3): Fe 370

fijaciones (4): nylon

pasamanos (5): PVC con alma de aluminio

##### acabado

barrotes (3): barnizado en horno con polvos epoxídicos

#### LIMPIEZA

limpiar con un trapo suave humedecido con agua y sin ningún producto que contenga disolventes o materiales abrasivos.

#### MANTENIMIENTO

transcurridos unos 12 meses desde la fecha de instalación, comprobar que los tornillos que fijan las distintas partes sigan bien apretados. el mantenimiento extraordinario debe ser efectuado como corresponde.

#### PRECAUCIONES DE USO

evitar usos impropios y no conformes con el producto. eventuales manipulaciones o instalaciones que no cumplan con las instrucciones del fabricante pueden menoscabar las cualidades certificadas en las pruebas de conformidad a las que previamente fue sometido el producto.



**30**  
D.U.M.  
12/2011



Albini & Fontanot S.p.A.  
**Sede legale ed amministrativa**  
via P. Paolo Pasolini, 6  
47853 Cerasolo Ausa  
Rimini, Italy

tel. +39.0541.90.61.11  
fax. +39.0541.90.61.25  
info@fontanot.it  
www.fontanot.it

cod. 065940000

Design: Centro Ricerche Fontanot

**ADIMEMBER**

Entero capitale Albini & Fontanot S.p.A.  
certificata (C) 90/90/01

